

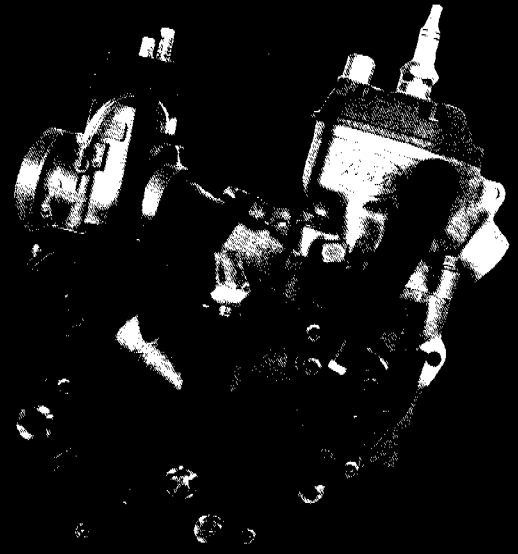

MOTOR TYP 490

Engine Type 490

80/85 cc - MX



TECHNISCHE DATEN		
MOTOR	80/I	85/I
BAUART	FLÜSSIGKEITSGEKÜHLTER EINZYLINDER - ZWEITAKT - OTTOMOTOR	
HUBRAUM	77,8 cm ³	82,9 cm ³
BOHRUNG/HUB	46,5/45,8 mm	48/45,8 mm
LEISTUNG MAX.	17,3 kW (23,5 PS)	17,6 kW (24 PS)
NENNDREHZAHL	12.000/min	
KRAFTSTOFF	SUPERKRAFTSTOFF ROZ 98, MIT ZWEITAKTÖL GEMISCHT	
MISCHUNGSVERHÄLTNIS	1:40 BEI VERWENDUNG VON HOCHWERTIGEM 2-TAKT-MOTORÖL IM ZWEIFELSFALL SETZEN SIE SICH BITTE MIT IHREM IMPORTEUR IN VERBINDUNG ODER MISCHEN SIE VORSICHTSHALBER 1:30	
•MASS "X"	0,42 - 0,45 mm	
ZÜNDZEITPUNKT	0,8 - 0,9 mm (13,6° - 14,4°) v.OT	
ZÜNDKERZE	BOSCH W 07 CS	
ELEKTRODENABSTAND	0,6 mm	
GETRIEBESCHMIERUNG	0,3 l HYPOIDOL SAE 80	
KÜHLFLÜSSIGKEIT	0,55 LITER, MISCHUNGSVERHÄLTNIS 2:1 - FROSTSCHUTZMITTEL: WASSER	
ZÜNDANLAGE	KONTAKTLOS GESTEUERTE THYRISTOR-ZÜNDANLAGE	

•DAS MASS "X" IST DER ABSTAND DER KOLBENOBERRANTE ZUR ZYLINDEROBERRANTE, GEMESSEN BEI OT-STELLUNG UND NIEDERGESpanNTEM ZYLINDER.

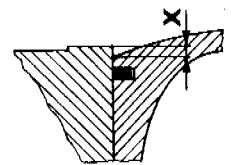

•Dimension "x" is the difference between the top edge and the cylinder top edge measured with piston at top dead center and with cylinder bolted down.

Technical Data		
Engine	80/I	85/I
Design	Liquid-cooled single-cylinder two-stroke engine	
Piston displacement	77,8 cc	82,9 cc
Bore/stroke	46,5/45,8 mm	48/45,8 mm
Performance max.	17,3 kW(23,5 HP)	17,6 kW (24 HP)
rpm at max. HP	12.000/min	
Fuel	SUPER fuel, research octane no 98, mixed with two-stroke oil	
Oil/gasoline ratio	1:40 when using 2-stroke competition oil. When in doubt, please contact your importeur or use 1:30 mix ratio to be on the safe side.	
•Dimension "x"	0,42 - 0,45 mm	
Ignition timing	0,8 - 0,9 mm (13,6 - 14,4 deg.) BTDC	
Spark plug	Bosch W 07 CS	
Electrode gap	0,6 mm	
Gear lubrication	0,3 l hypoid oil SAE 80	
Coolant	0,55 litres mixture 2:1 of anti-freeze and water	
Ignition system	solid-state thyristor ignition system	

GETRIEBEÜBERSETZUNGEN		Gear box ratios	
PRIMÄRÜBERSETZUNG	23:75	Primary Ratio	
1.GANG	13:37	1st gear	
2.GANG	16:34	2nd gear	
3.GANG	18:31	3rd gear	
4.GANG	21:30	4th gear	
5.GANG	23:28	5th gear	
6.GANG	24:26	6th gear	
ORIGINAL-ÜBERSETZUNG	14:52 (SUPER-MINI 17"/14")	Original Final Drive Ratio	
HINTERRAD	14:62 (PRO-LEVER 21"/18")		
LIEFERBARE KETTENRÄDER VORNE	13,14,15	Available Chain Drive Sprockets	
LIEFERBARE KETTENRÄDER HINTEN	48,50,52 (SUPER-MINI 17"/14") 60,62,64 (PRO-LEVER 21"/18")	Available Final Drive Sprockets	

VERGASER-GRUNDEINSTELLUNG			Basic carburettor setting
VERGASERTYPE	PHBH 28 GS	PHSB 35 MS	carburettor type
HAUPTDÜSE	150	165	Main jet
NADELDÜSE	270 T	268 BH	Needle jet
LEERLAUFDÜSE	55	58	Idling jet
DÜSENNADEL	X 24	K 36	Jet needle
NADELPOSITION	2. VON OBEN / 2nd from top		Needle position
LUFTREGULIER-SCHRAUBE OFFEN	1,5 UMDR./turn		Pilot air adjusting screw open
SCHIEBER	40	45	Throttle valve
STARTDÜSE	70	70	Starting jet

TOLERANZEN - EINBAUSPIELE		Tolerances and Fitting clearances	
KOLBENEINBAUSPIEL	0,04 mm	piston fitting clearances	
KOLBENRING - STOSSPIEL	0,1-0,3 mm	piston ring end gap	
PLEUELLAGER-RADIAL	0,021-0,032 mm	connecting rod bearing-radial clearances	
GETRIEBEWELLEN-AXIALSPIEL	0,1-0,2 mm	transmission shaft end float	
KUPPLUNGSDRUCKFEDERN-LÄNGE	2,4 β - 27 mm	clutch springs-length	

DICHTUNGSSTÄRKEN		Gasket Thicknesses	
MOTORGEHÄUSE	0,3 mm	crank case	
KUPPLUNGSDECKEL	0,3 mm	clutch cover	
WASSERPUMPENDECKEL	0,3 mm	water pump cover	
ZÜNDUNGSDECKEL	0,3 mm	ignition cover	
ZYLINDERFUSSDICHTUNG	NACH BEDARF/as required (0,05/0,2/0,3/0,5/1,0mm)	cylinder bottom gasket	
ZYLINDERKOPFDICHTUNG	1 mm	cylinder head gasket	

ANZUGSDREHMOMENTE			Tightening Torques
BUNDMÜTERN AM ZYLINDERFUSS	M 8	29 Nm	collar nuts cylinder bottom
ZYLINDERKOPFSCHRAUBEN	M 7	18 Nm	cylinder head bolts
BUNDMUTTER-SCHWUNG	M 12x1	54-59 Nm	flywheel collar nut
MUTTER FÜR PRIMÄRRAD	M 14x1,5	74-78 Nm	nut for primary sprocket
SECHSKANTSCHRAUBE	M 10	74-78 Nm	bolt for inner clutch hub
KUPPLUNGSMITNEHMER			
MOTORGEHÄUSE- UND DECKELSCHRAUBEN	M 6	8 Nm	crank case and cover bolts
MOTORBEFESTIGUNGS-SCHRAUBE	M 8	35 Nm	engine mounting bolts
SCHWINGARMBOLZEN	M 12	88 Nm	swing arm pivot

MOTORGEHÄUSE / Engine case



BILD Fig	TEILENUMMER Part number	STK Qty	BILD Fig	TEILENUMMER Part number	STK Qty
1	490.30.000.044	1	40	490.30.001.000	1
2	490.30.000.000	1	41	490.30.025.000	1
5	510.30.026.100	1	42	490.30.090.000	2 $\phi 9,8$
6	500.30.026.000	1	43	580.30.020.000	1
7	490.30.010.000	2	44	0770 160030	1 16x3
8	490.34.021.000	1	45	490.30.029.000	1 M10
9	501.33.025.000	1	46	0603 102151	1 10x15x1
10	0912 060163	1	47	0912 060253	6 M6x25
11	0912 060453	4	49	490.30.095.000	1
12	0912 060303	4			
13	510.30.022.000	1	50	490.35.001.000	1
14	550.07.016.001	0,3	51	490.35.002.000	1
15	490.30.039.000	1	52	0912 060163	3 M6x16
20	490.30.051.044	1	53	0137 060000	7 B6
21	490.30.051.000	1			
22	490.30.056.000	2		DICHTUNGSSATZ Gasket set	
23	490.30.052.000	2		490.30.100.000	1 80cc
24	490.30.053.000	2		490.30.100.100	1 85cc
25	0084 040083	4			
26	490.30.054.000	1			
27	490.30.050.000	1			
28	543.30.061.000	1			
29	0912 060203	8			
30	490.30.002.000	1			
31	490.30.040.000	1			

KURBELTRIEB / Crankshaft, Piston

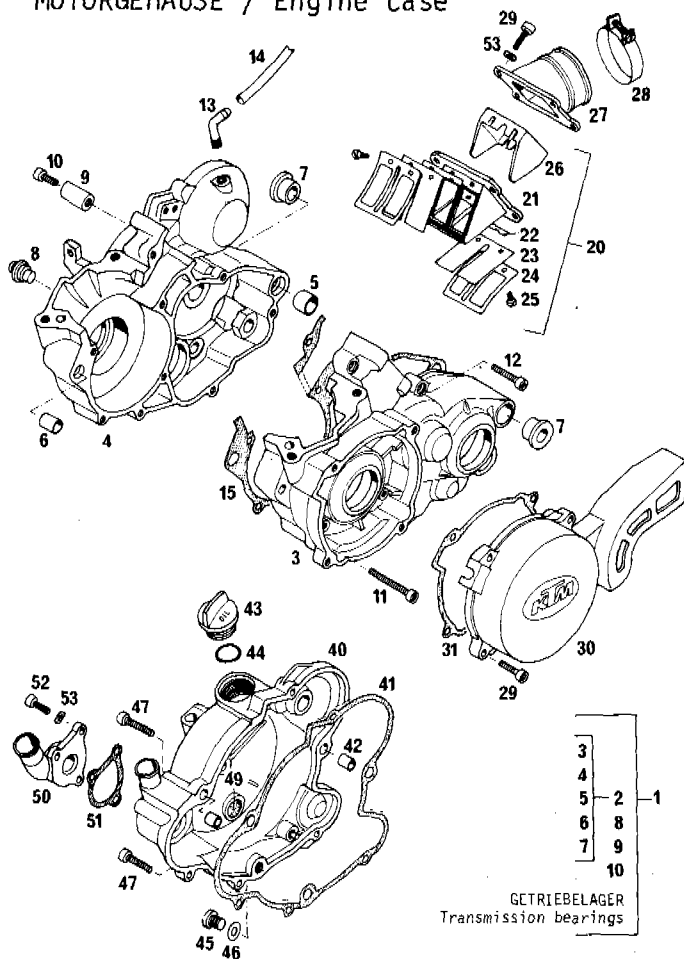

BILD Fig.	TEILENUMMER Part number	STK Qty	
1	490.30.018.000	1	45,8 mm
2	490.30.015.044	1	
3	490.30.034.000	1	14x18x14,5
4	0888 030050	2	3x5
5	540.30.081.100	x	25x35x0,10
5	540.30.081.200	x	25x35x0,15
5	540.30.081.300	x	25x35x0,30
6	490.30.023.000	2	NJ 205
7	0760 253571	1	25x35x7 DF
8	0760 223570	1	22x35x7 DF
9	0137 120000	1	B12
10	490.30.021.000	1	M12x1
11	490.32.000.023	1	23-2
12	500.30.048.000	1	14,1x30x1
13	0936 140155	1	M14x1,5
14	0760 102260	1	10x22x6
15	490.35.005.000	1	
16	0471 090010	1	A9x1
20	490.30.007.000	1	46,5 mm 80cc
20	490.30.007.500	1	48,0 mm 85cc
21	490.30.032.000	1	46,5 mm 80cc
21	490.30.032.500	1	48,0 mm 85cc
22	490.30.033.000	1	
23	490.30.074.000	2	SRC14

x = NACH BEDARF / as required

ZYLINDER / cylinder

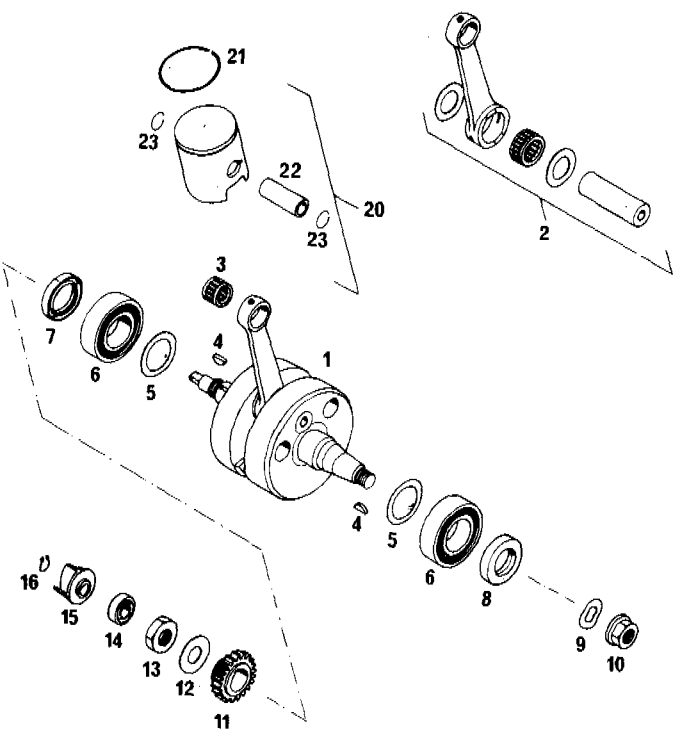

BILD Fig.	TEILENUMMER Part number	STK Qty	
1	490.30.005.000	1	46,5 mm 80cc
1	490.30.005.500	1	48,0 mm 85cc
2	490.30.030.505	x	0,05mm
2	490.30.030.520	x	0,20mm
2	490.30.030.530	x	0,30mm
2	490.30.030.550	x	0,50mm
2	490.30.030.600	x	1,00mm
3	0835 080253	4	M8x25
4	490.30.028.000	4	M8
5	543.35.027.000	1	
6	570.05.027.000	2	
10	490.30.006.000	1	80/85cc
11	490.30.036.000	1	80cc
11	490.30.036.500	1	85cc
12	490.30.036.020	1	80/85cc
13	490.30.079.000	5	M7x34,5
14	0125 070003	5	A7,4
15	500.30.680.000	5	CU7,2x12x0,2

x = NACH BEDARF / as required

VERGASER 35 mm / Carburettor

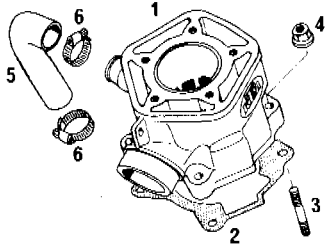
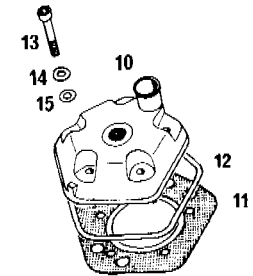

BILD Fig.	TEILENUMMER Part number	STK Qty	BILD Fig.	TEILENUMMER Part number	STK Qty
1-37	490.31.101.044	1	27	0603 082121	1 8x12x1
	DELL'ORTO PHSB35MS		28	490.31.513.000	1 M8
1	490.31.135.045	1 NR.45	29	490.31.108.000	1 2x27
2	490.31.134.000	1 K36	30	490.31.174.000	1
3	490.31.121....*	1	31	490.31.110.000	1
4	490.31.122.000	1 NR.1	32	490.31.111.000	1
5	570.31.523....*	1	33	0127 050003	3 B5
6	151.31.123.0...*	1	34	0084 050203	3 M5x20
7	490.31.151.0...*	1	35	0603 182415	1 18x24x1,5
8	572.31.120.300	1 300	36	490.31.114.000	1 M18x1
9	490.31.109.000	2 9794 gr.3	37	490.31.112.000	1
10	490.31.119.000	1	95	501.31.137.000	2
11	490.31.116.000	1	96	830.13.096.000	2
12	490.31.138.000	1	99	490.31.199.000	1
13	570.31.525.100	1 M6x0,75			
14	490.31.227.000	1			
15	490.31.128.000	1 1,5x41x44			
16	490.31.127.000	1			
17	490.31.131.000	1			
18	490.31.130.000	1 1,25x230			
19	0799 025055	1 RS2,5x5,5			
20	0963 045103	1 M4,5x10			
21	490.31.149.000	1			
22	490.31.117.000	1 M7x0,75			
23	570.31.515.000	1			
24	490.31.106.000	1			
26	490.31.212.000	1			

* AUFGESTEMPELTE NUMMER (GRÖSSE) ANGEBEN!

Please quote printed number (size)!

VERGASER 28 mm / Carburettor

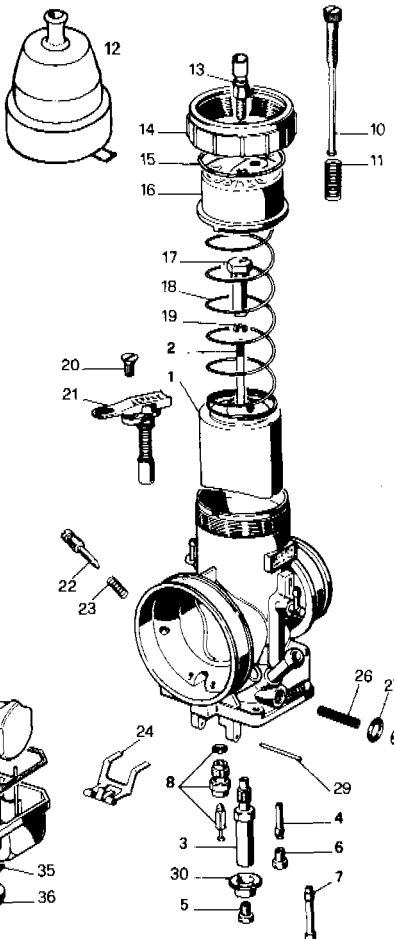

BILD TEILENUMMER STK
Fig. Part number Qty

BILD TEILENUMMER STK
Fig. Part number Qty

1-39	490.31.101.144	1	DELL'ORTO PHBH28GS
1	490.31.135.140	1	
2	490.31.134.124	1	
3	490.31.221.***	1	
4	570.31.523.***	1	
5	151.31.123.0.**	1	
6	570.31.551.0.**	1	
7	572.31.120.200	1	
8	490.31.109.100	1	
9	570.31.525.100	1	
10	570.31.524.000	2	
11	490.31.127.100	1	
12	490.31.130.100	1	
13	490.31.131.100	1	
14	0799 025055	1	
15	490.31.128.100	1	
16	0963 045143	1	
17	501.31.149.000	1	
18	0770 080010	1	
19	570.31.517.000	1	
20	570.31.515.000	1	

*AUFGESTEMPELTE NUMMER (GRÖSSE) ANGEBEN!
Please quote printed number (size)!

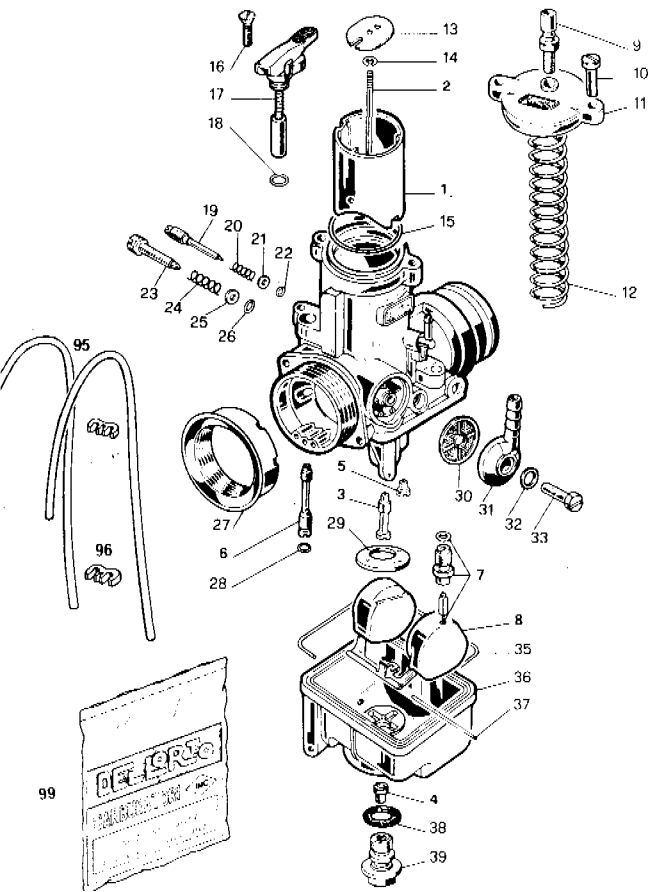
ZÜNDANLAGE / Ignition system



BILD TEILENUMMER STK
Fig. Part number Qty

1	490.31.002.000	1	MOTOPLAT 0619 303
2	0085 050203	3	M5x20
3	0137 050003	3	
4	0125 050003	3	
10	490.31.031.000	1	MOTOPLAT 9635401
11	490.31.031.051	1	
12	510.31.011.000	1	
13	510.31.005.000	1	
14	100.11.072.100	1	
15	440.11.076.180	x	
16	490.31.013.000	1	
17	490.31.113.000	1	
20	510.31.006.200	1	
21	510.31.010.100	1	
22	560.31.093.370	1	W07CS (370S2S)
30	0933 060163	4	
31	0125 060003	2	
32	0021 060003	2	
33	0985 060003	4	

x = NACH BEDARF
as required

KUPPLUNG / Clutch

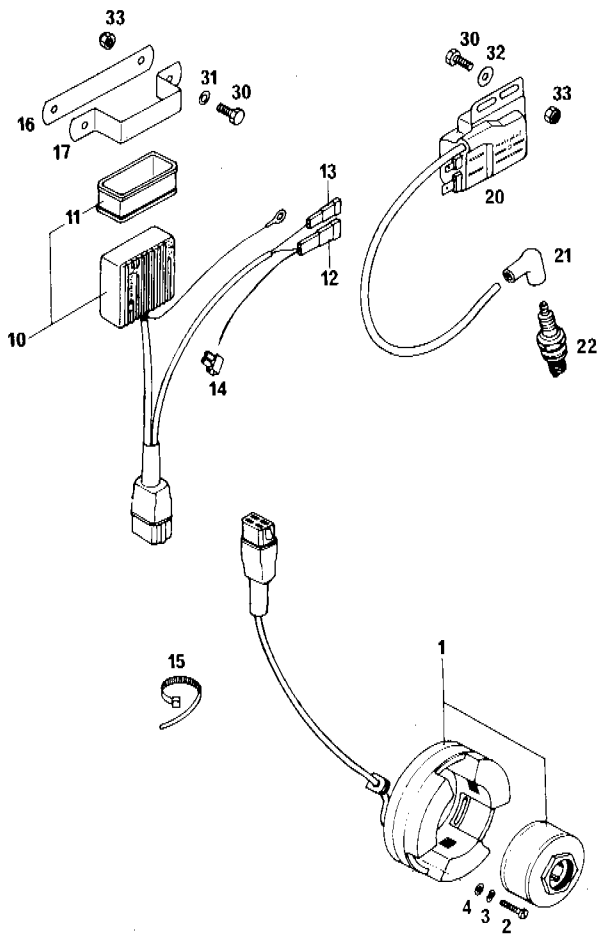
BILD TEILENUMMER STK
Fig Part number Qty



BILD Fig	TEILENUMMER Part number	STK Qty
1	490.32.001.075	1 75-Z
2	490.32.001.000	1
3	0338 050095	6 A5x9,5
4	490.32.012.000	2 17,2x30x1,5
5	490.32.095.000	1 17x21x17,2
6	490.32.096.000	1 21x25x17
7	490.32.003.000	1
8	490.32.004.000	7
9	490.32.105.000	6
10	490.32.002.000	1
11	490.32.011.000	1
12	490.32.006.000	6
13	490.32.007.000	1
14	0991 060203	6 M6x20
20	0799 050000	1 RS5
21	490.32.008.100	1
22	490.32.010.050	2 AS 0619
23	490.32.010.000	1 AXK 0619
24	490.32.009.000	1
30	490.32.013.000	1
31	0770 082020	1 8,2x2
32	490.32.015.000	1
33	0984 060163	1 M6x16
34	501.34.027.000	1 M6x20

SCHALTUNG / Shifting Mechanism

BILD TEILENUMMER STK
Fig Part number Qty

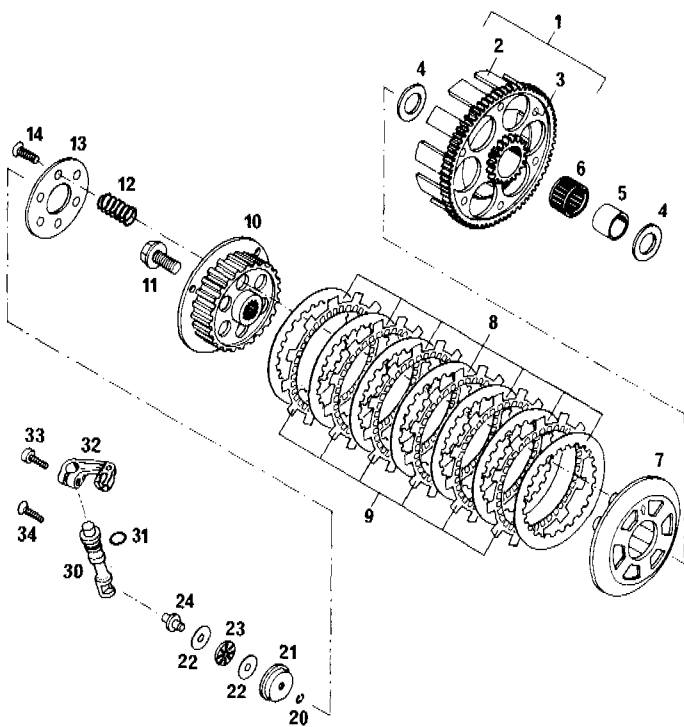

BILD Fig	TEILENUMMER Part number	STK Qty
1	490.34.005.100	1
2	490.34.007.000	1
3	490.34.008.000	1
4	490.34.009.000	1
5	490.34.013.000	1
6	490.34.014.000	1
10	490.34.022.000	1
11	0760 122050	2 12x20x5
20	490.34.012.000	1
21	501.34.026.000	1 30x38x7,5
22	490.34.015.000	1
23	0991 060253	1 M6x25
24	490.34.023.100	1
25	490.34.024.044	1
26	0471 100010	1 A10x1
30	490.34.004.000	1
31	490.34.002.100	2
32	490.34.003.000	1
33	490.34.001.100	1

KICKSTARTER / Kickstarter

BILD TEILENUMMER STK
Fig Part number Qty

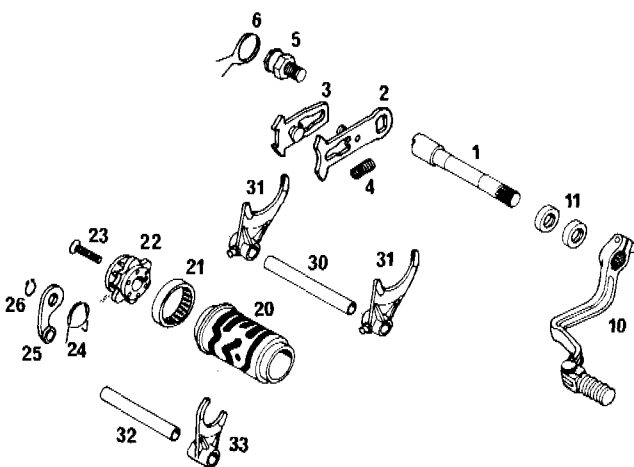

BILD Fig	TEILENUMMER Part number	STK Qty
1	490.33.026.000	1
2	490.33.020.000	1
3	490.33.022.000	1 29-Z
4	490.33.024.000	1 18-Z
5	490.33.021.000	1
6	490.33.027.000	1
7	0991 060203	2 M6x20
8	490.33.023.000	1
9	490.33.031.000	1 14,3x20x1
10	490.33.028.000	1
20	490.33.036.044	1
21	0760 142460	1 14x24x6
22	0984 060183	1 M6x18
23	0797 060003	1 J6

GETRIEBE I / Transmission I

BILD TEILENUMMER STK
Fig Part number Qty

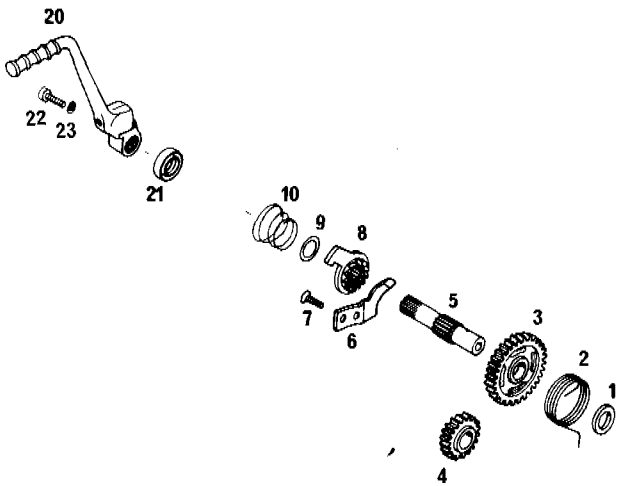

BILD Fig	TEILENUMMER Part number	STK Qty
1	490.33.011.000	1 13-Z
2	490.33.010.000	1 16-Z
3	490.33.008.000	1 18/21-Z
5	490.33.007.000	1 23-Z
6	490.33.009.000	1 24-Z
7	490.33.090.000	2 WA17x2
8	490.33.013.000	1 12,1x25x1
9	490.33.097.000	1 12x12
10	0625 982030	1 98203

GETRIEBE II / Transmission II

BILD TEILENUMMER STK
Fig Part number Qty

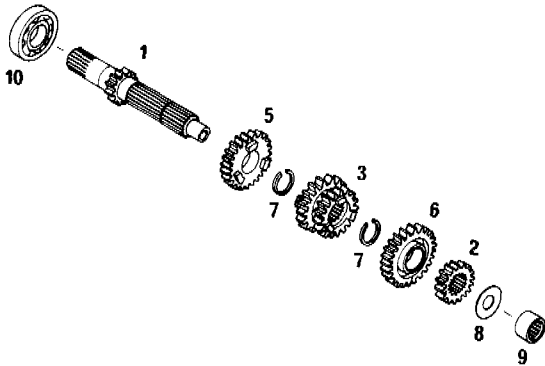

BILD Fig	TEILENUMMER Part number	STK Qty
1	490.33.001.000	1 37-Z
2	490.33.006.000	1 34-Z
3	490.33.003.000	1 31-Z
4	490.33.004.000	1 30-Z
5	490.33.002.000	1 28-Z
6	490.33.005.000	1 26-Z
7	490.33.012.000	1
8	490.33.029.013	x 13-Z
8	490.33.029.014	1 14-Z 1/2x5/16"
8	490.33.029.015	x 15-Z
9	490.33.091.000	4 AS20x1,75
10	490.33.013.000	1 12,1x25x1
11	490.33.097.000	1 12x12
12	0625 060040	1 6004
13	0760 263570	1 26x35x7
14	490.33.092.000	1 19,5x1,5
15	490.33.017.000	1 20x26x11
16	544.03.135.000	1

x = NACH BEDARF / as required

KÜHLSYSTEM / Cooling system

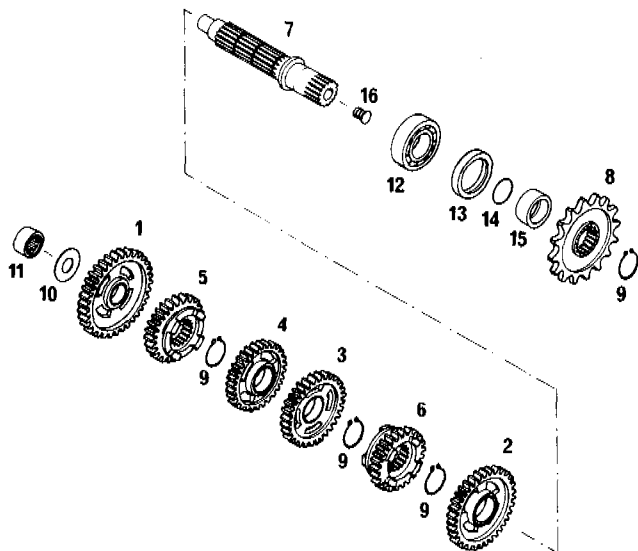

BILD TEILENUMMER STK
Fig part number Qty

1	490.35.007.100	1	(4.5041)
2	490.35.016.000	1	
4	545.35.134.000	1	
5	500.35.025.001	0,35	
6	543.35.027.000	1	
7	100.01.020.000	4	
8	550.07.016.001	0,4	
9	543.35.031.000	3	
10	0021 060003	6	
11	0797 060003	6	
12	0934 060003	6	
13	0983 480193	1	
15	310.05.142.000	3	

SPEZIALWERKZEUGE / Special tools

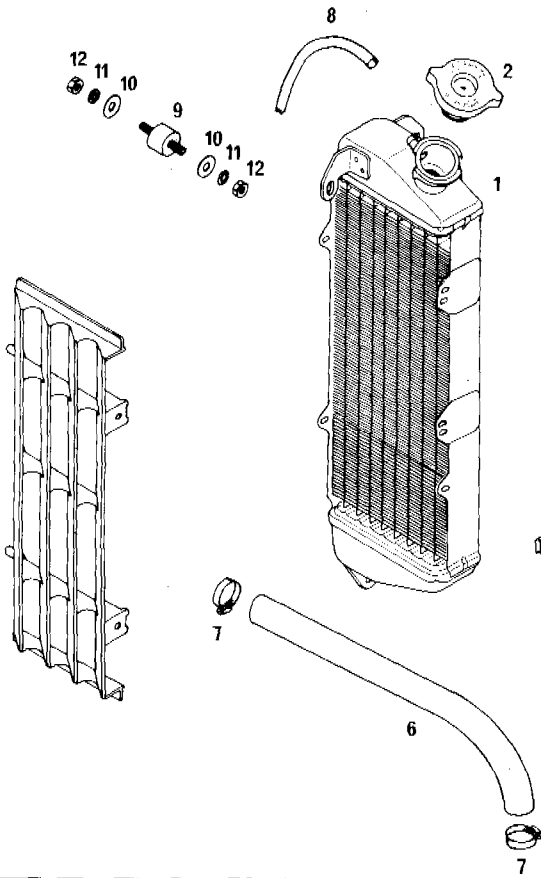

BILD TEILENUMMER
Fig. Part number

1	490.12.001.000	
3	490.12.003.000	
4	490.12.004.000	
5	490.12.005.010	∅10
6	490.12.005.012	∅12
7	490.12.005.025	∅25
8	510.12.009.000	M27x1
9	510.12.011.000	
10	501.12.013.000	
11	510.12.014.000	
12	510.12.016.000	
13	151.12.017.000	
14	151.12.018.000	
15	501.12.030.000	
16	SELBSTGEFERTIGT self-made	
17	SELBSTGEFERTIGT self-made	
18	6.899.786	LOCTITE 242 BLAU/blue

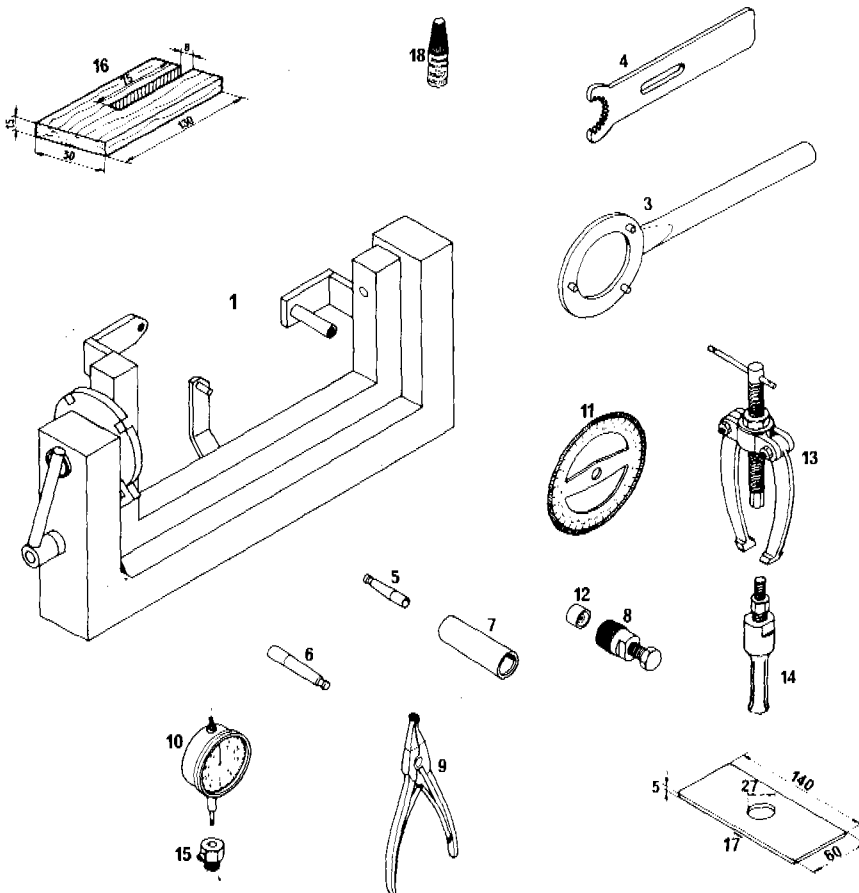

80/85cc MX'87