

KTM
ORIGINAL SPARE PARTS

'92

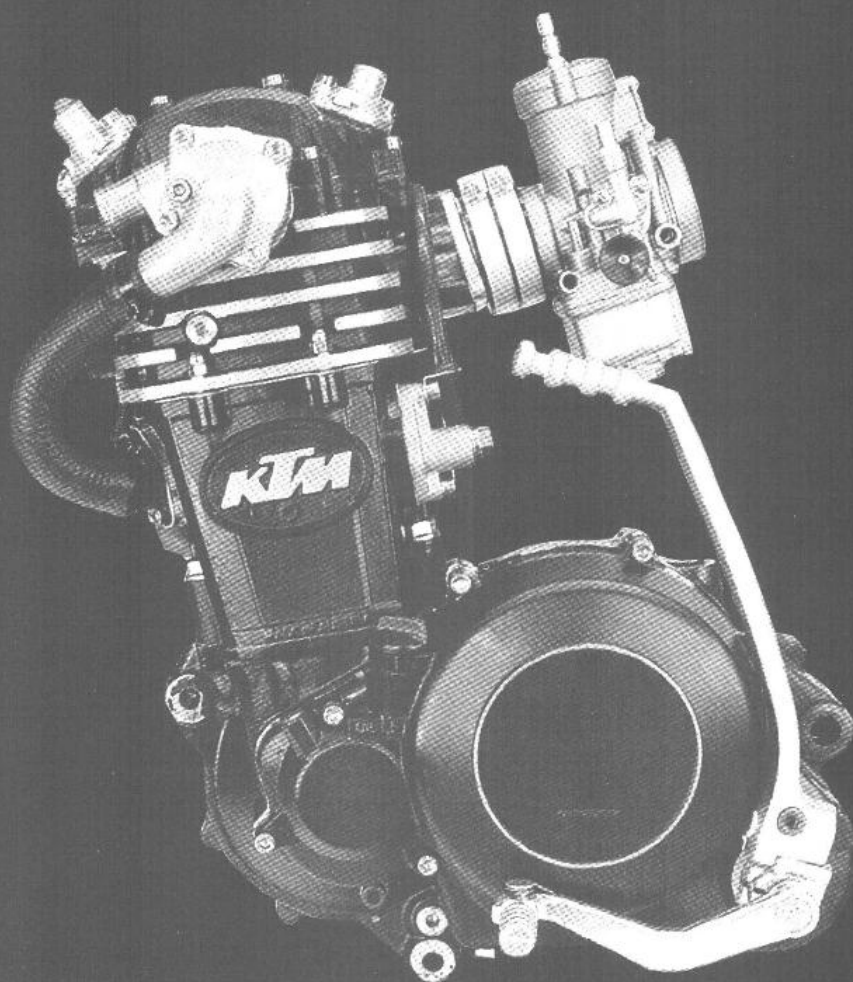

4-TAKT-MOTOR TYP 580
4-stroke Engine Type 580

Art.-Nr. 3.203.51
2.92

500/600 LC4

Technische Daten — Motor

	500 LC4	600 LC4
Bauart	1-Zylinder 4-Takt Otto-Motor, flüssigkeitsgekühlt	
Hubraum	496 ccm ³	553 ccm ³
Bohrung/Hub	90/78 mm	95/78 mm
Kraftstoff	bleifreier Superkraftstoff mit mindestens ROZ 95	
Steuerung	4 Ventile über Kipphebel u. 1 obenliegende Nockenwelle gesteuert, Antrieb der Nockenwelle mit Einfachkette	
Motor- und Getriebsschmierung	Druckumlaufschmierung mittels Eaton-Ölpumpe mit Naßsumpf	
Motoröl	1,7 Liter vollsynthetisches Motoröl 5W 50	
Zündanlage	kontaktlos gesteuerte Thyristor-Zündanlage mit elektr. Zündverstellung Typ SEM	
Zündzeitpunkt	Grundeinstellung: Leerlauf 0—2° v. OT (1.200/min) Verstellung ab 1.700/min bis max. 30° v. OT bei 5.000/min	
Generator	12 V 130 W	
Zündkerze	Champion A5 YC	
Elektrodenabstand	0,6 mm	
Kühlung	Flüssigkeitskühlung, permanente Umwälzung der Kühlflüssigkeit durch mechanische Wasserpumpe	
Kühlflüssigkeit	1,2 Liter: 40 % Frostschutz/60 % Wasser (mindestens — 25° C)	
Starthilfe	Dekompressor handbetätigt — Kalt- und Warmstarteinrichtung am Vergaser	

Technical Data — Engine

	500 LC4	600 LC4
Design	Liquid cooled, single cylinder 4-stroke engine	
Displacement	496 cc	553 cc
Bore/stroke	90/78 mm	95/78 mm
Fuel	unleaded premium gasoline with a least RON 95	
Valve timing	4 valves over rocker arm and 1 overhead camshaft, camshaft drive through single chain	
Engine and transmission lubrication	forced-feed lubrication through Eaton-Oilpump with oil sump filter	
Engine oil	1,7 liters full-synthetic engine oil 5W 50	
Ignition System	contactless thyristor ignition with electronic advanced system type SEM	
Ignition timing	basic adjustment: Idling: 0—2° BTDC (1.200/rpm) adjustment from 1.700/rpm to max. 30° BTDC 5.000/rpm	
Generator	12 V 130 W	
Spark plug	Champion A5 YC	
Spark plug gap	0,6 mm (0.028 in.)	
Cooling system	Liquid cooled, permanent rotation of cooling liquid through mechanic driven waterpump	
Cooling liquid	1,2 litres: 40 % antifreeze/60 % water (at least — 25° C, — 13° F)	
Starting procedure	Decompressor hand actuated — Cold and warm start knob on carburator	

Vergaser-Grundeinstellung

Basic carburetor setting

	600 MX 600 D-XC	600 E-XC	600 E-GS ungedrosselt	600 E-XC gedrosselt	500/600 E-GS BRD, A	600 E-GS CH	
Typ	PHM 38 SD	PHM 38 SD	PHM 38 SD	PMH 38 SD	PHM 38 SD	PMH 38 SD	Type
Hauptdüse	195	190	185	120	135	140	Main jet
Nadeldüse	DR 272	DR 272	DR 272	DR 268	DR 268	DR 264	Needle jet
Leerlaufdüse	55	52	52	38	38	38	Idling jet
Düsenadel	K 51	K51	K 51	K 51	K 51	SK 395	Jet needle
Nadelpos. von oben	2	2	2	3	3	3	Needle pos. from top
Gemischreg.							Mixture adjusting
Schraube offen (Umdr.)	1,5	1,5	1,5	2	2	—	screw open (turn)
Gasschieber	40	40	40	40	40	50	Throttle valve
Startdüse	45	45	45	45	45	45	Starting jet

Getriebeübersetzungen

Primär- übersetzung	Getriebeübersetzung	Original-Über- setzung Hinterrad
30 : 81	1. Gang 14:35	MX 15:50
	2. Gang 15:24	D-XC 15:50
	3. Gang 18:21	E-XC 15:50
	4. Gang 20:19	E-GS 16:45
	5. Gang 27:21	16:40

Gear ratios

Primary- ratio	Transmission	Original final- drive ratio
30 : 81	1 st gear 14:35	MX 15:50
	2 nd gear 15:24	D-XC 15:50
	3 rd gear 18:21	E-XC 15:50
	4 th gear 20:19	E-GS 16:45
	5 th gear 27:21	16:40

Toleranzen, Einbauspiele

Kolbeneinbauspiel	0,04—0,05 mm
Kolbenring-Stoßspiel Kompressionsringe Ölabstreifring	0,20—0,60 mm 0,30—0,80 mm
Axialspiel Kurbelwelle	0,10—0,20 mm
Kurbelzapfenschlag	max. 0,04 mm
Axialspiel Getriebewellen	0,10—0,20 mm
Axialspiel Ölpumpe	0,10—0,20 mm
Ventilspiel kalt	0,15 mm
Ventilführungsspiel	0,02—0,04 mm

Tolerance, assembly clearance

Piston assembly clearance	0,04—0,05 mm
Piston ring play compression rings oil scrape ring	0,20—0,60 mm 0,30—0,80 mm
Crankshaft end play	0,10—0,20 mm
Crankshaft pin	max. 0,04 mm
Transmission shaft end play	0,10—0,20 mm
Oilpump end play	0,10—0,20 mm
Valve play cold	0,15 mm
Valve guide play	0,02—0,04 mm

(mm x 0,03937 = inch)

Anzugsdrehmomente - Motor

Sechskantmutter Primärrad M20x1,5	170 Nm + Loctite 242
Bundmutter Schwungrad M12x1 links	60 Nm
Sechskantmutter für Kupplungsmitnehmer M18x1,5	80 Nm
Kickstarter-Anschlagschraube M12x1,5	70 Nm
Innensechskantschrauben der Ölpumpe M6	8 Nm
Sechskantschraube Nockenwellenrad M10	35 Nm
Innensechskantschrauben Zylinderkopf-Oberteil M6	8 Nm
Zylinderkopfschrauben M10	60 Nm
Bundmuttern am Zylinderfuß M10	40 Nm
Kettenradmutter M 20x1,5	70 Nm
Ölablaßschraube	50 Nm
Verschlußschraube Steuerkettenspanner	20 Nm
Kontermuttern Ventileinstellschrauben	20 Nm

Tightening torques

Hexagon nut at primary gear M20x1,5	170 Nm + Loctite 242
Collar nut at left flywheel M12x1	60 Nm
Hexagon nut for clutch carrier M18x1,5	80 Nm
Kickstarter stop screw M12x1,5	70 Nm
Hexagon recess screws at oilpump M6	8 Nm
Hexagon screw at camshaft gear wheel M10	35 Nm
Hexagon screw at upper part of cylinder head M6	8 Nm
Cylinder head screws M10	60 Nm
Collar nuts at cylinder foot M10	40 Nm
Sprocket hex. nut M 20x1,5	70 Nm
Oil drain plug	50 Nm
Plug automatic tensioner	20 Nm
Hex nut valve adjusting screws	20 Nm

(Nm x 0,738 = ft.lbs)

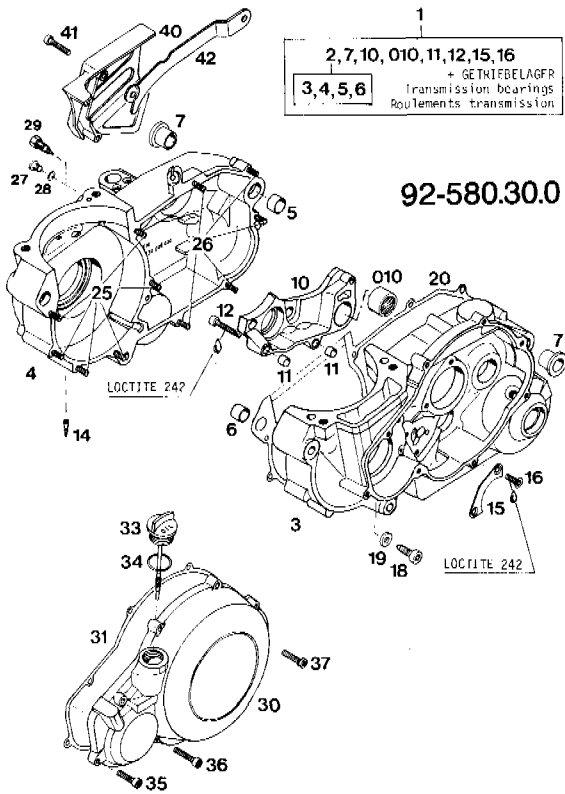

Motorgehäuse/Crank case

Bild Fig	Teilnummer Part number	Stk Qty	Bild Fig	Teilnummer Part number	Stk Qty
1▲	580.30.000.744	1	26	0912 060303	5
2▲	580.30.000.700	1	27	490.30.029.000	1
5	501.30.027.000	1	28	580.38.032.010	1
6	510.30.026.100	1	29	6241 850	1
7	501.30.010.000	2	30	580.30.001.100	1
10	580.30.011.500	1	31	580.30.025.000	1
010	580.33.097.000	1	33	580.30.020.044	1
11	490.30.090.000	2	34	0770 160030	1
12	0912 060403	2	35	0912 060253	5
12	0912 060353	1	36	0912 060303	1
14	491.30.450.050	1	37	0984 060252	2
15	565.30.017.000	1	40	580.30.050.600	1
16	0991 060123	2	41	0912 060303	2
18	580.30.080.000	1	42	580.30.047.515	1
19	580.30.081.000	1	—	580.30.100.000	1
20	580.30.039.000	1		Dichtungssatz	
25	0912 060553	6		Gasket set	

▲ = NEUTEILE '92/NEW PARTS '92

91-580.30.1

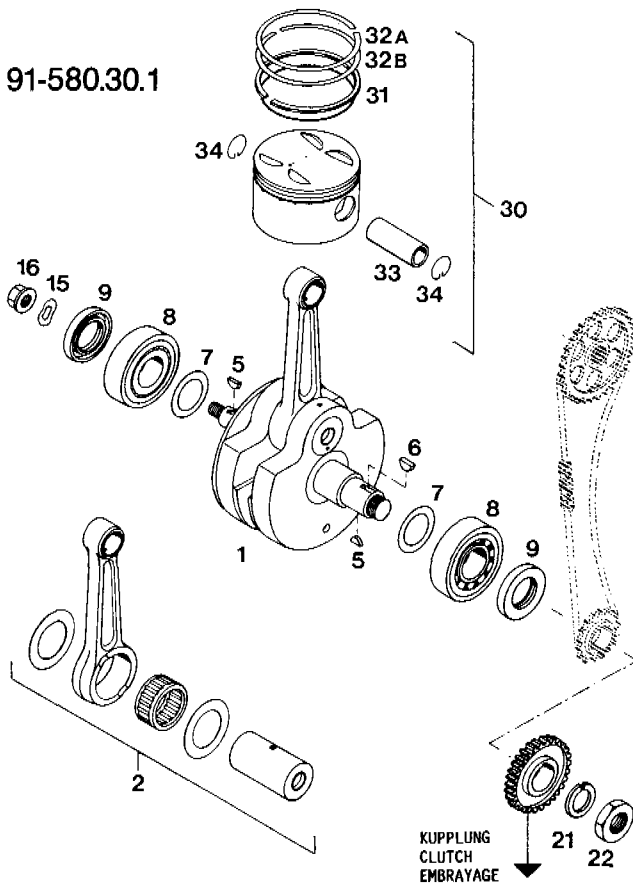

Kurbelwelle, Kolben/Crankshaft, Piston

Bild Fig	Teilnummer Part number	Stk Qty	Bild Fig	Teilnummer Part number	Stk Qty
1	580.30.018.600	1	30	580.30.607.000	1
2	580.30.015.644	1		95 mm/600 LC4	
5	0888 030050	2	31	580.30.031.000	1
6	0888 050650	1		90 mm/500 LC4	
7	560.30.081.000	X 0,1 mm	31	580.30.631.000	1
7	560.30.081.100	X 0,15 mm		95 mm/600 LC4	
7	560.30.081.200	X 0,3 mm	32a	580.30.032.000	1
8	580.30.082.000	2		90 mm/500 LC4	
9	0760 305272	2	32a	580.30.632.000	1
15	0137 120000	1		95 mm/600 LC4	
16	510.30.028.100	1	32b	580.30.132.000	1
21	580.30.019.000	1		90 mm/500 LC4	
22	0936 200155	1	32b	580.30.732.000	1
30	580.30.007.000	1		95 mm/600 LC4	
			33	580.30.033.000	1
			34	580.30.074.000	2

X = nach Bedarf/as required

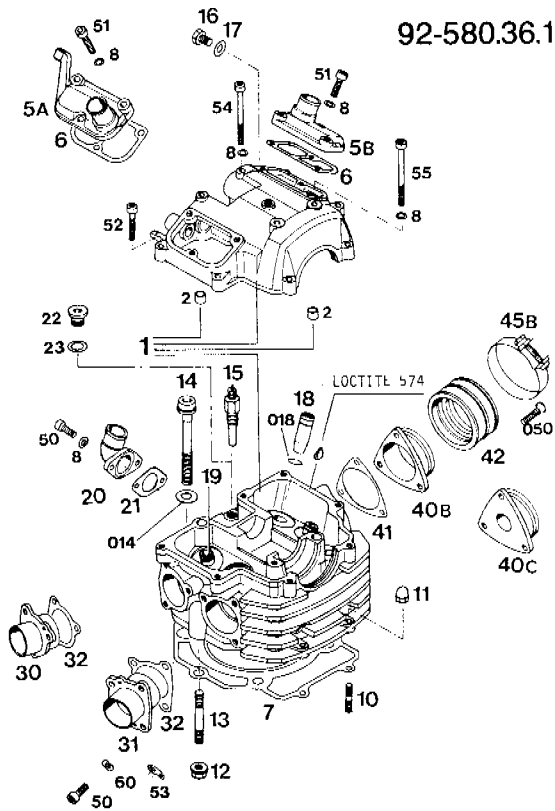

92-580.36.1

Zylinderkopf/Cylinder head

Bild Fig	Teilnummer Part number	Stk Qty	Bild Fig	Teilnummer Part number	Stk Qty
1	580.36.020.600 LC4'91 500	1	18	580.36.026.600	2
1	580.36.620.600 LC4'91 600	1	19	580.36.126.600	2
2	490.30.090.000	2	20	565.35.006.000	1
5a	580.36.152.500	1	21▲	565.35.106.000	1
5b	580.36.052.100	1	22	0908 100003	1
6	580.36.053.000	2	23	580.38.032.010	1
7	580.30.036.000 90,5 mm/500 LC4	1	30	580.36.040.000	1
7	580.30.136.100 95,3 mm/600 LC4	1	31	580.36.140.000	1
8	580.36.065.000	12	32	580.36.041.000	2
10	0551 060303	2	40b	581.36.042.000	1
11	0587 060003	2	40c	581.36.142.023	1
12	490.30.028.000	2	41	581.36.043.000	1
13	543.30.043.000	2	42	581.36.044.100	1
14	580.36.098.000	4	45b	565.30.061.000	2
14	580.36.099.000	2	50	0912 060163	8
15	420.11.252.000	1	50	0991 060163	3
16	0933 080123	1	51	0912 060203	6
17	580.38.032.000	1	52	0912 060253	6
18	0993 012000	4	53	510.05.074.000	2
			54	0912 060603	2
			55	0912 060703	2
			60	0137 060000	6

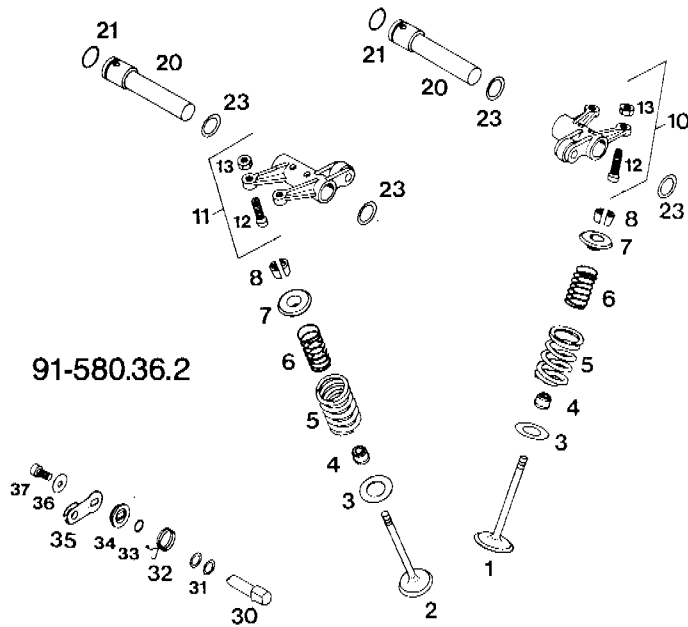

91-580.36.2

Ventiltrieb/Valve drive

Bild Fig	Teilnummer Part number	Stk Qty	Bild Fig	Teilnummer Part number	Stk Qty
1	580.36.030.000 36 mm	2	21	580.36.095.000	2
2	580.36.031.000 30 mm	2	23	0988 162205	X 0,5 mm
3	580.36.027.100	4	23	0988 162210	X 1 mm
4	580.36.028.000	4	30	580.36.050.100	1
5	580.36.029.100	4	31	543.34.015.000	X
6	580.36.129.100	4	31	543.34.015.200	X
7	580.36.032.500	4	32	580.36.059.100	1
8	580.36.033.000	8	33	0770 100221	1
10	580.36.060.644	1	34	580.36.048.000	1
11	580.36.061.644	1	35	580.36.049.500	1
12	580.36.062.600	4	36	0021 060003	1
13	0934 070756	4	37	0912 060103	1
20	580.36.056.000	2			

X = nach Bedarf/as required

92-580.30.2

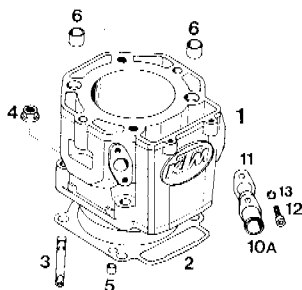

Zylinder/Cylinder

Bild Fig	Teilnummer Part number	Stk Qty	Bild Fig	Teilnummer Part number	Stk Qty
1	580.30.005.100 90 mm/500 LC4	1	5	490.30.090.000	2
1	580.30.605.100 95 mm/600 LC4	1	6	510.30.026.100	2
2	580.30.030.000	1	10a	580.35.010.000	1
3	0835 100451	4	11	580.35.037.000	1
4	0331 100003	4	12	0912 060163	2
			13▲	580.36.065.000	2

92-580.38.1

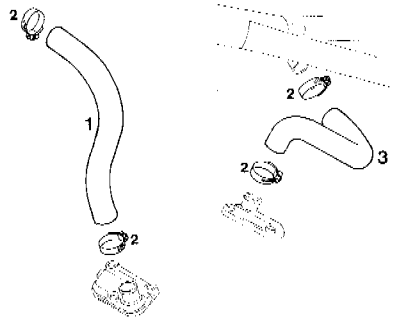

Motorentlüftung/Breather system

Bild Fig	Teilenummer Part number	Stk Qty
1▲	580.35.025.800	1
2	100.01.020.000	4
3▲	580.35.125.800	1

91-580.36.0

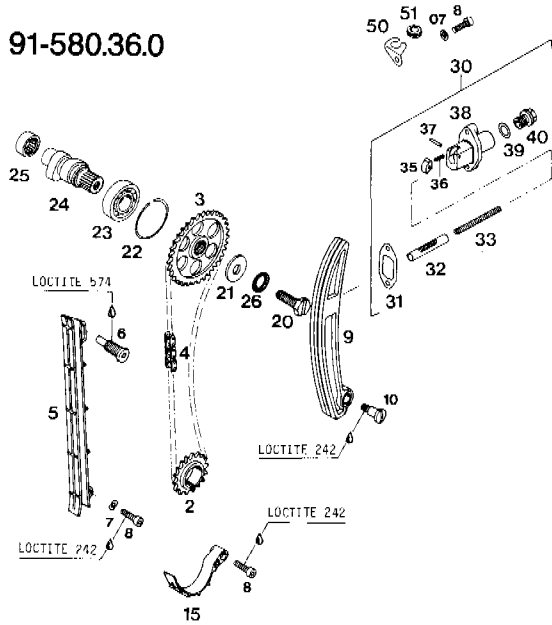

Steuertrieb/Timing drive

Bild Fig	Teilenummer Part number	Stk Qty	Bild Fig	Teilenummer Part number	Stk Qty
2	580.36.014.000	1	25	580.36.097.000	1
3	580.36.011.000	1	26	360.03.014.200	1
4	580.36.013.000	1	30	580.36.003.144	1
5	580.36.001.000	1	31	580.36.005.100	1
6	580.36.009.000	1	32	580.36.004.100	1
7	0137 060000	1	33	580.36.006.100	1
07	580.36.065.000	2	35	580.36.007.100	1
8	0912 060203	4	36	580.36.007.050	1
9	580.36.002.000	1	37	0402 031780	1
10	0923 080120	1	38	580.36.003.100	1
15	580.36.018.000	1	39	580.36.022.000	1
20	580.36.112.500	1	40	580.36.008.100	2
21	580.36.012.000	1	50	580.38.339.000	1
22	580.36.096.000	1	51	310.11.027.000	1
23	0625 060040	1			
24	580.36.010.000	1			
	249 Grad				

92-580.38.0

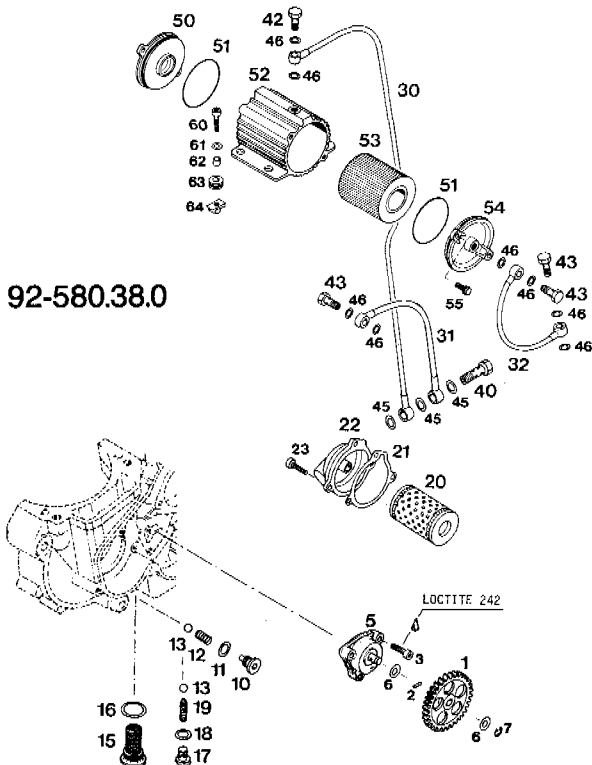

Schmiersystem/Lubrication system

Bild Fig	Teilenummer Part number	Stk Qty	Bild Fig	Teilenummer Part number	Stk Qty
1	580.38.001.000	1	30	580.38.234.600	1
2	0402 025980	1	31	580.38.334.600	1
3	0912 060202	3	32	580.38.134.600	1
5▲	580.38.007.100	1	40	580.38.033.100	1
6▲	580.38.007.755	1	42	580.38.130.000	1
7▲	0799 060000	1	43	580.38.030.000	3
10	580.38.070.044	1	45	580.38.032.010	3
11	580.38.022.100	1	46	580.38.032.000	8
12	580.38.026.100	1	50	580.38.041.000	1
13	546.37.099.000	2	51	0770 056020	2
15	580.38.019.000	1	52	580.38.043.000	1
16	580.38.017.000	1	53	580.38.044.000	1
17	0908 120153	1	54	580.38.042.000	1
18	580.38.022.000	1	55	0010 050163	4
19	580.38.023.200	1	60	0912 050203	3
20	580.38.005.000	1	61	0125 050003	3
21	580.30.041.000	1	62	544.31.032.050	3
22	580.30.008.600	1	63	310.08.060.000	3
23	0912 060163	3	64	546.03.048.200	3

Vergaser Dell'orto/Carburettor Dell'orto

Vergasereinstellung beachten!

Pay attention to the carburettor setting!

91-580.31.0



Bild Fig	Teilnummer Part number	Stk Qty	Bild Fig	Teilnummer Part number	Stk Qty
1-52	580.31.601.044	1	10	520.31.138.000	1
	Sport		11	570.31.525.100	1
1-52	580.31.601.544	1	12	520.31.126.000	2
1	580.31.135.040	1	13	490.31.131.000	1
1	580.31.135.050	1	14	0799 025055	1
	E-GS CH		15	544.31.530.000	1
2	490.31.134.051	1	17	570.31.524.000	2
2	490.31.134.395	1	18	580.31.127.000	1
	E-GS CH		19	570.31.525.000	1
3	580.31.121.272	1	20	572.31.155.000	1
	Sport		21	580.31.153.000	1
3	580.31.121.268	1	22	570.31.549.000	1
	TÜV		23	572.31.150.100	1
3	580.31.121.264	1	25	580.31.180.000	1
	E-GS CH		26	580.31.181.000	1
4	570.31.523.195	1	27	0964 040143	3
	Sport/MX, D-XC		28	0912 040123	2
4	580.31.523.190	1	31	570.31.522.000	1
	Sport E-XC		34	570.31.572.000	1
4	570.31.523.185	1	35	570.31.515.000	1
	Sport E-GS		36	570.31.517.000	1
4	570.31.523.140	1	37	570.31.519.000	1
	E-GS CH		38	520.31.116.000	1
4	570.31.523.135	1	39	570.31.573.000	1
	E-GS TÜV		41	0933 060163	1
4	570.31.523.120	1	43	570.31.513.000	1
	E-XC TÜV		44	151.31.112.000	1
5	151.31.123.055	1	45	501.31.174.000	1
	Sport/MX, D-XC		48	570.31.508.000	1
5	151.31.123.052	1	50	570.31.511.100	1
	Sport E-XC, E-GS		52	570.31.514.000	1
5	151.31.123.038	1	53	580.31.199.000	1
	TÜV		90	490.31.138.000	1
05	490.31.122.000	1	95	501.31.137.000	3
6	580.31.151.045	1	96	830.13.096 000	2
7	572.31.120.300	1			
08	570.31.509.000	1			
9	580.31.140.038	1			

91-580.31.5

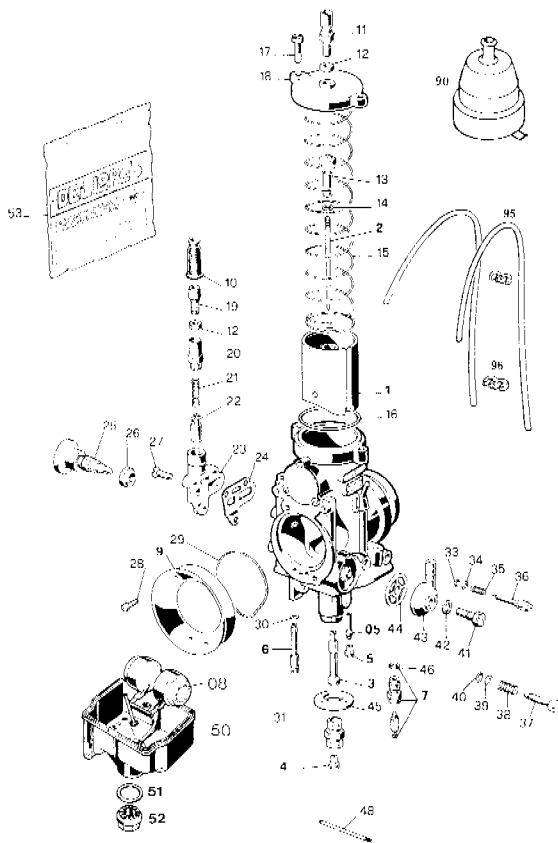
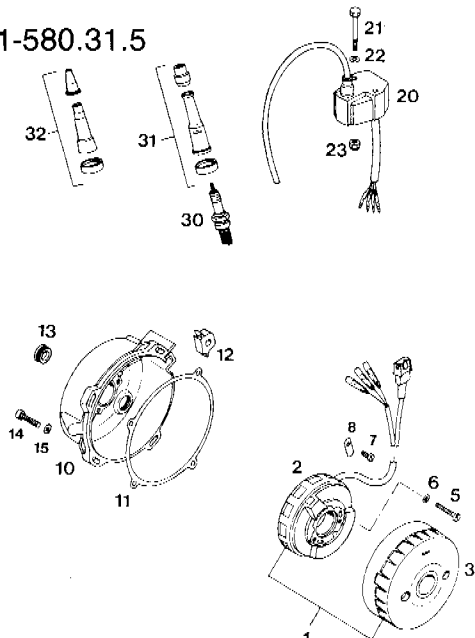

Zündanlage/Ignition system

Bild Fig	Teilnummer Part number	Stk Qty	Bild Fig	Teilnummer Part number	Stk Qty
1	580.31.002.000	1	13	580.30.002.050	1
2	580.31.002.050	1	14	0912 060253	4
3	580.31.002.051	1	15	0125 060003	4
5	0084 050303	3	20	580.31.006.000	1
6	0125 050003	3	21	0931 060503	2
7	0500 050083	1	22	0125 060003	2
8	500.31.003.000	1	23	0985 060003	2
10	580.30.002.200	1	30	580.31.093.005	1
11	580.30.040.000	1	31	580.31.010.000	1
12	580.31.004.000	1	32	580.31.410.044	1

92-580.33.1

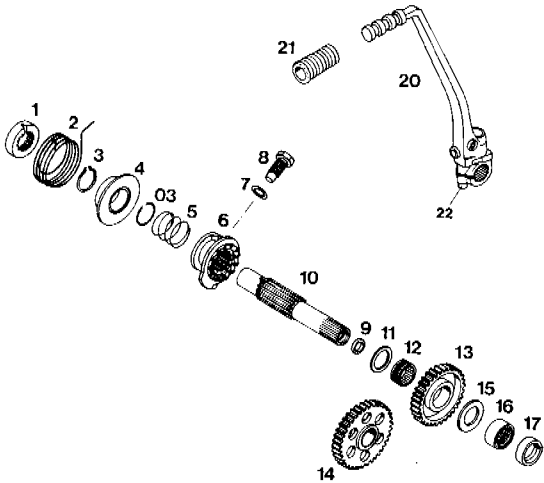

Kickstarter/Kickstarter

Bild Fig	Teilenummer Part number	Stk Qty	Bild Fig	Teilenummer Part number	Stk Qty
1	580.33.026.100	1	13	580.33.022.600	1
2	580.33.020.000	1	14	580.33.024.000	1
3	520.33.096.000	1	15	565.32.012.000	1
03	520.33.090.100	1	16	580.33.090.000	1
4	580.33.037.000	1	17	0760.223270	1
5	580.33.028.000	1	20	580.33.036.044	1
6	580.33.023.100	1	21	580.33.040.000	X
7	580.38.022.000	1	22	0912.070203	1
8	580.33.033.000	1		M 7x20	
9▲	546.32.090.000	1	22	0912.060203	X
10▲	580.33.021.200	1		M 6x20	
11	580.33.031.000	1			
12	565.33.098.000	1			

X = nach Bedarf/as required

90-580.33.2

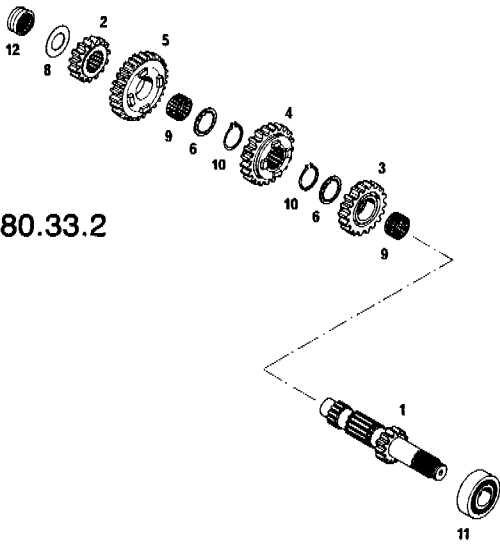

Getriebe I/Transmission I

Bild Fig	Teilenummer Part number	Stk Qty
1	565.33.002.300	1
2	565.33.010.300	1
3	565.33.004.300	1
4	565.33.006.300	1
5	565.33.008.300	1
6	565.33.016.300	2
8	565.33.015.000	1
9	565.33.099.000	2
10	520.33.096.000	2
11	0625.201029	1
12	565.33.093.000	1

90-580.33.3

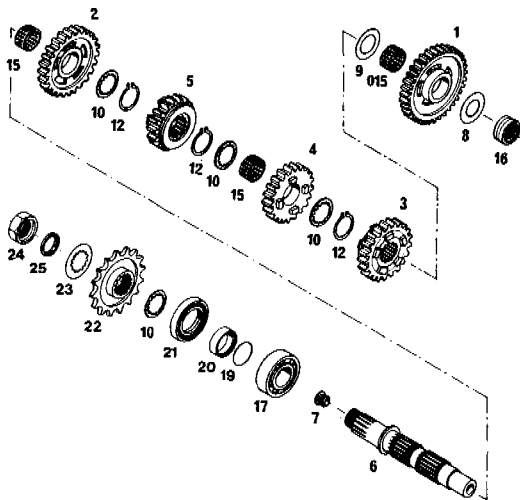

Getriebe II/Transmission II

Bild Fig	Teilenummer Part number	Stk Qty	Bild Fig	Teilenummer Part number	Stk Qty
1	565.33.005.300	1	16	565.33.093.000	1
2	565.33.013.300	1	17	490.30.023.000	1
3	565.33.007.300	1	19	0770.020220	1
4	565.33.009.300	1	20	580.33.017.000	1
5	565.33.011.300	1	21	0760.324771	1
	21-Z		22	580.33.029.014	1
6	580.33.003.100	1		14-Z	
7	500.33.001.000	1	22	580.33.029.015	1
8	565.33.015.000	1		15-Z	
9	565.33.018.300	1	22	580.33.029.016	1
10	565.33.016.300	4		16-Z	
12	520.33.096.000	3	23	510.33.031.000	1
15	565.33.099.000	2	24	580.33.032.100	1
015	565.33.098.000	1	25	580.33.030.000	1

92-580.32.1

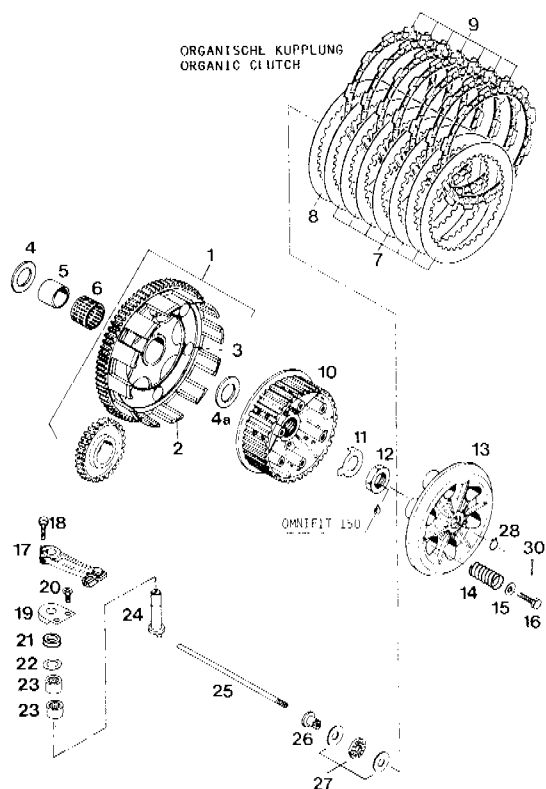

Kupplung/Clutch

Bild Fig	Teilnummer Part number	Stk Qty	Bild Fig	Teilnummer Part number	Stk Qty
1	580.32.101.144	1	14	543.32.001.000	6
2	580.32.001.000	1	15	502.32.050.000	6
3	580.32.007.000	6	16	0933 060203	6
4	565.32.012.000	1	17	580.32.014.000	1
4a	546.32.013.000	1	18	0912 060203	1
5	565.32.096.000	1	19	545.32.013.000	1
6	565.32.095.000	1	20	0991 060122	2
7	580.32.112.000	7	21	545.32.093.000	1
8	580.32.012.500	1	22▲	490.33.031.200	1
			23▲	503.32.095.000	2
			24	545.32.015.100	1
9	580.32.011.000	7	25	580.32.017.000	1
			26	565.32.032.300	1
10	565.32.002.500	1	27	543.32.030.000	1
11	565.32.018.000	1	28	0471 100010	1
12	0936 181505	1	30	0094 150223	1
13	565.32.003.100	1			

92-580.34.0

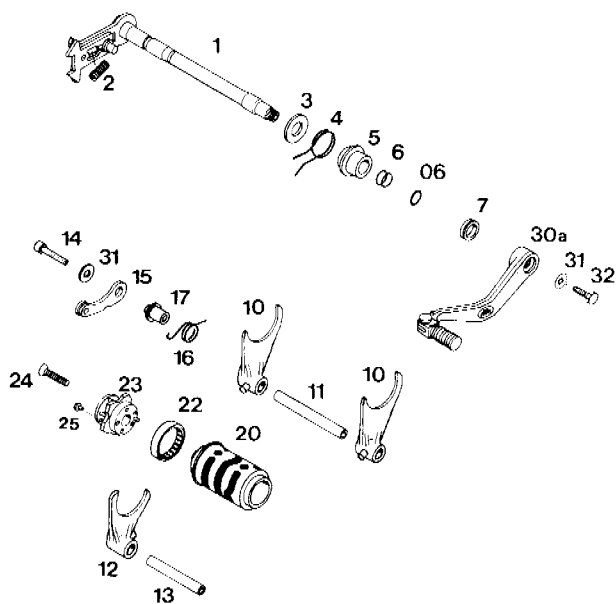

Schaltung/Shifting mechanism

Bild Fig	Teilnummer Part number	Stk Qty	Bild Fig	Teilnummer Part number	Stk Qty
1▲	580.34.005.244	1	14	0912 060553	1
2	565.34.013.100	1	15	580.34.024.544	1
3	580.34.010.000	1	16	580.34.023.500	1
4	580.34.014.000	1	17	580.34.017.500	1
5	580.34.020.000	1	20	580.34.012.000	1
6	0770 123021	2	22	501.34.026.000	1
			23	580.34.015.544	1
06	0770 100221	1	24	0991 060303	1
			25	580.34.016.500	1
7	580.33.027.000	1	30a	580.34.022.000	1
10▲	580.34.002.200	2	31	502.32.050.000	1
11	580.34.004.000	1	32	0933 060163	1
12	580.34.001.100	1			
13	580.34.003.000	1			

92-580.35.0

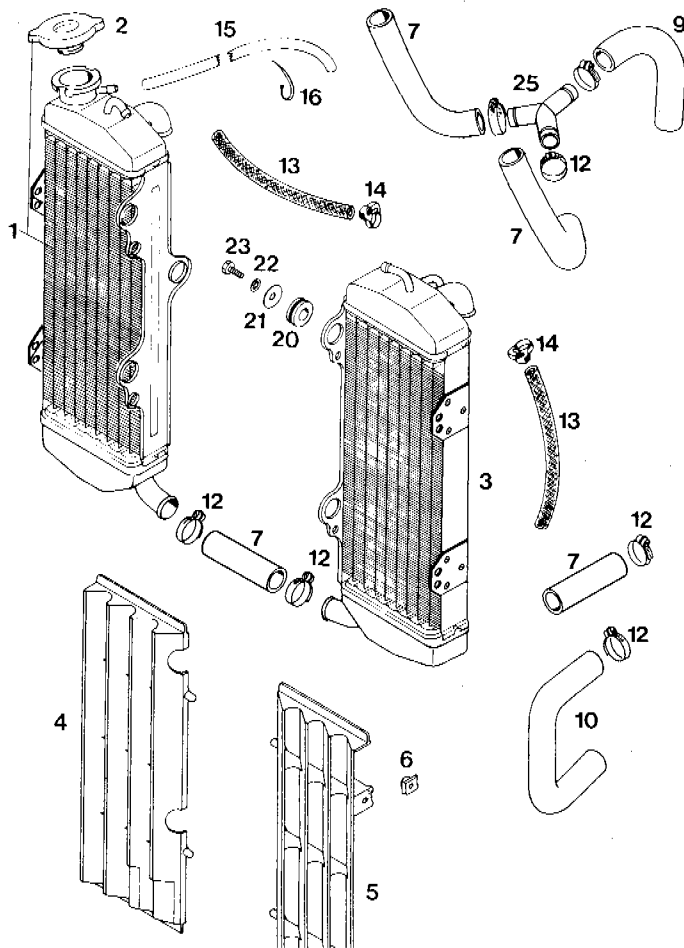

Kühlsystem / Cooling system

Bild Fig	Teilnummer Part number	Stk Qty	Bild Fig	Teilnummer Part number	Stk Qty
1▲	580.35.008.700	1	13	544.35.024.001	0,48m
2	580.35.016.000	1	14	544.35.023.100	4
3▲	580.35.007.700	1	15	550.07.016.001	0,45m
4	580.35.134.000	1	16	440.11.076.155	X
5	580.35.034.000	1	20	410.01.052.000	6
6	502.35.033.000	4	21	510.06.097.000	6
7	565.35.025.001	0,70m	22	0797 060003	6
9	546.35.025.000	2	23	0933 060123	6
10	502.35.025.700	1	25	565.35.026.000	1
12	100.01.020.000	12			

X = nach Bedarf/as required

92-580.35.2

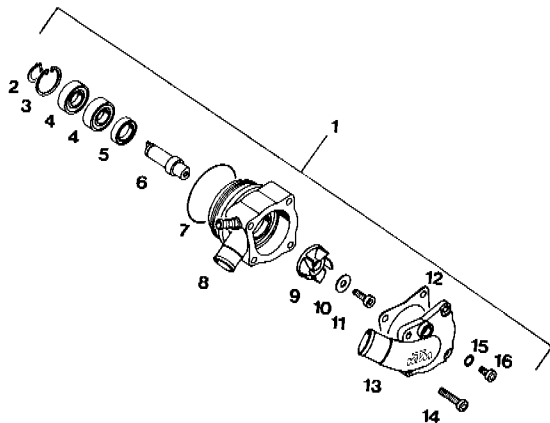

Wasserpumpe / Water pump

Bild Fig	Teilnummer Part number	Stk Qty
1▲	580.35.050.644	1
2	0471 120010	1
3	0472 280120	1
4	0625 060016	2
5	0760 152472	1
6	544.35.010.000	1
7	0770 047015	1
8▲	580.35.002.600	1
9	565.35.005.300	1
10	0021 050003	1
11	0912 050123	1
12	565.35.003.300	1
13	565.35.001.300	1
14	0984 060183	4
15	580.36.065.000	1
16	0912 060103	1

88-580.12.1

HOLZKLOTZ - SELBSTGEFERTIGT
WOODEN BLOCK - HOME MADE

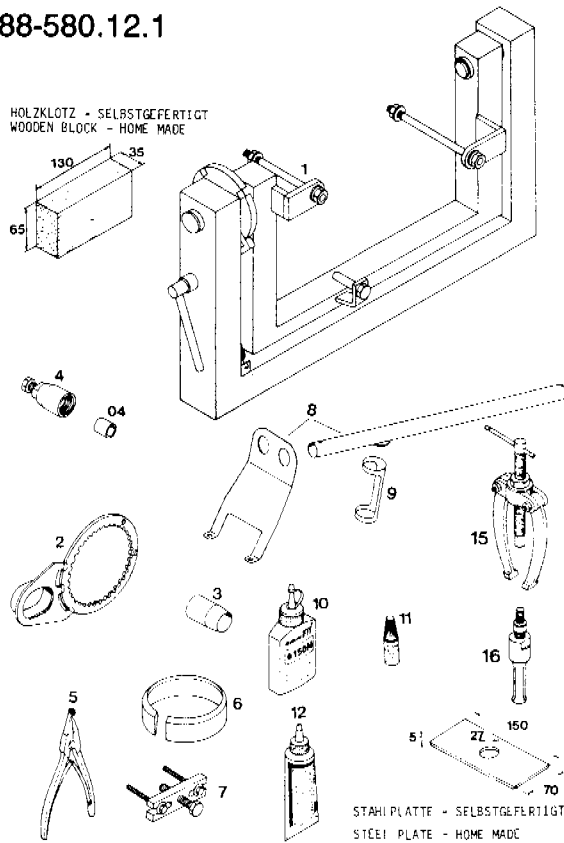
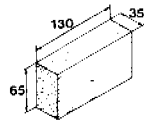

STAHPLATTE - SELBSTGEFERTIGT
STEEL PLATE - HOME MADE

Spezialwerkzeuge/Special tools

Bild Fig	Teilenummer Part number	Stk Qty
1	580.12.001.000	1
2	580.12.003.000	1
3	580.12.005.025 Ø 25	1
4	580.12.009.000	1
04	510.12.016.000	1
5	510.12.011.000	1
6	580.12.015.090 Ø 90/500 cc	1
6	580.12.015.095 Ø 95/600 cc	1
7	580.12.021.000	1
8	580.12.019.000	1
9	6 276 470	1
10	090.43 Omnifit 150 green	X
11	6 899 785 Loctite blue	X
12	6 899 683 Loctite red	X
15	151.12.017.000	1
16	151.12.018.100	1

X = nach Bedarf/as required

Konstruktions- und Ausführungsänderungen vorbehalten.
All Rights reserved to make alterations to design and model

KTM
ORIGINAL SPARE PARTS

'92



4-TAKT-MOTOR TYP 580
4-stroke Engine Type 580

500/600 LC4

KTM SPORT MOTORCYCLE

GESELLSCHAFT M. B. H.

5230 MATTIGHOFEN - AUSTRIA