



MUSTER ✓

ERSATZTEILKATALOG FAHRGESTELL '93



**500
SX**



**550
MXC**

SPARE PARTS MANUAL CHASSIS '93

ART. NR. 3.203.58

93-500.01.0 TELEGABEL 125-550 '93
FRONT FORK



BILD FIG.	TEILENUMMER PART NUMBER	BEZEICHNUNG DESCRIPTION	STK. QTY.
2A*	502.01.402.500	GABELBEIN LINKS K1MS93 FORK LEG L/S 125 SX	1
2A*	502.01.402.300	GABELBEIN LINKS K1GE93 FORK LEG L/S 125 EXC, 125 EGS	1
2A*	546.01.402.200	GABELBEIN LINKS K23E93 FORK LEG L/S 250/300 EXC USA	1
2A*	546.01.402.300	GABELBEIN LINKS K23G93 FORK LEG L/S 250/300 EXC, 250/300 EGS	1
2A*	546.01.402.400	GABELBEIN LINKS K235SCM93 FORK LEG L/S 250/300 SX USA, 300 MXC 550 MXC	1
2A*	546.01.402.500	GABELBEIN LINKS K23M93 FORK LEG L/S 250/300 SX EUROPA	1
2A*	565.01.402.200	GABELBEIN LINKS BAK593MX FORK LEG L/S 500 SX	1
2B*	502.01.502.500	GABELBEIN RECHTS K1MS93 FORK LEG R/S 125 SX	1
2B*	502.01.502.300	GABELBEIN RECHTS K1GE93 FORK LEG R/S 125 EXC, 125 EGS	1
2B*	546.01.502.200	GABELBEIN RECHTS K23E93 FORK LEG R/S 250/300 EXC USA	1
2B*	546.01.502.300	GABELBEIN RECHTS K23G93 FORK LEG R/S 250/300 EXC, 250/300 EGS	1
2B*	546.01.502.400	GABELBEIN RECHTS K235SCM93 FORK LEG R/S 250/300 SX USA, 300 MXC, 550 MXC	1
2B*	546.01.502.500	GABELBEIN RECHTS K23M93 FORK LEG R/S 250/300 SX EUROPA	1
2B*	565.01.502.200	GABELBEIN RECHTS BAK593MX FORK LEG R/S 500 SX	1
32	546.01.032.044	GABELBR. UNT. KPL. X=18MM/D=57MM BOT. FORK PLATE	1
33	501.01.033.100	GABELSCHAFTTROHR L=244 '91 FORK STEM	1
34	546.01.034.000	GABELBRÜCKE OBEN X=18MM/D=57MM TOP FORK PLATE	1
38	564.01.038.000	LENKERKLEMMBRÜCKE HANDLEBAR CLAMP	2
39	564.01.039.000	LENKER AUFNAHME HANDLEBAR SUPPORT	1
40	564.01.040.000	GUMMIBÜCHSE RUBBER BUSHING	4
41	564.01.041.100	DISTANZROHR 10,2X12X44 SPACER TUBE	2

* = NEUTEILE / NEW PARTS

X = NACH BEDARF / AS REQUIRED



BILD FIG.	TEILENUMMER PART NUMBER	BEZEICHNUNG DESCRIPTION	STK. QTY.
42	564.01.042.000	SCHEIBE 10,5X32X2 WASHER	2
042	564.01.142.000	SCHEIBE 10,5X31 WASHER	2
43	564.01.043.000	SCHRAUBE M20X1,5 SCREW	1
44	564.01.044.000	SCHEIBE 21X38X3 WASHER	1
53	0912 080303	ISK-SCHRAUBE DIN912-M8X30 A H SCREW	13
56	0984 100702	ISK-SCHRAUBE DIN7984-M10X70 ALLEN HEAD SCREW	2
57	0912 070203	ISK-SCHRAUBE DIN912-M7X20 ALLEN HEAD SCREW	2
58	0934 070003	SK-MUTTER DIN934-M7 HEX NUT	2
59	0985 100003	SS-MUTTER DIN985-M10 S L NUT	2
60	0931 050403	SK-SCHRAUBE DIN931-M5X40 HEX HEAD SCREW	1
61	0931 050453	SK-SCHRAUBE DIN931-M5X45 HEX HEAD SCREW	1
62	0125 050003	SCHEIBE DIN125-A5,3 FLAT WASHER	2
64	0985 050003	SS-MUTTER DIN985-M5 S L NUT	2
66	0933 050163	SK-SCHRAUBE DIN933-M5X16 H H SCREW	2
67	546.01.094.100	BUNDBÜCHSE FÜR GLEITSCHUTZ BUSHING	2

93-500.01.0

TELEGABEL 125-550 '93
FRONT FORK

BILD FIG.	TEILENUMMER PART NUMBER	BEZEICHNUNG DESCRIPTION	STK. QTY.
80	546.01.084.100	O-RINGTRÄGER M DICHTLIPPE '91 O-RING SUPPORT	1
81	542.01.081.000	KEGELROLLENLAGER SKF 331274 TAPER ROLLER BEARG	2
83	546.01.184.000	STEUERKOPFABDICHTUNG OBEN TOP SEAL	1
86	542.01.086.000	SCHUTZRING CAP	1
90A	546.01.090.000	SCHUTZFÖHRUNG LINKS WEISS PROTECT.GUIDE L/S	1
90B	546.01.190.000	SCHUTZFÖHRUNG RECHTS WEISS PROTECT.GUIDE R/S	1
91A	546.01.091.000	GLEITSCHUTZ LINKS WEISS FORK TUBE PROTECT.	1
91B	546.01.191.000	GLEITSCHUTZ RECHTS WEISS FORK TUBE PROTECT.	1
92*	502.01.492.000	KLEBEFOLIE GLEITSCHUTZ LI '93 DECAL L/S	1
--*	502.01.592.000	KLEBEFOLIE GLEITSCHUTZ RE '93 DECAL R/S	1
93	565.01.092.000	SCHELLE CLAMP	1
95*	502.01.493.000	KLEBEFOLIE "UP-SIDE-DOWN" '93 DECAL UP SIDE DOWN	2
96	571.01.008.000	MASSEKABEL GROUND CABLE	1
97	0933 060123	SK-SCHRAUBE DIN933-M6X12 H H SCREW	1
99	542.12.035.000	RINGSCHLÜSSEL SW32 STEER.HEAD WRENCH	1

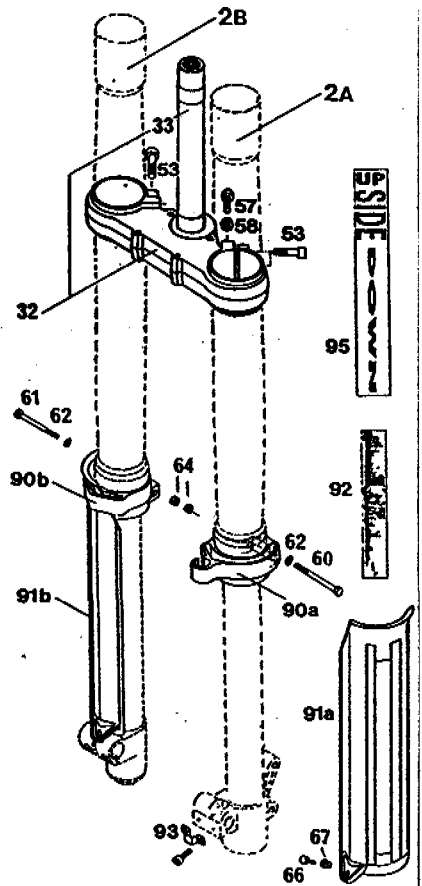
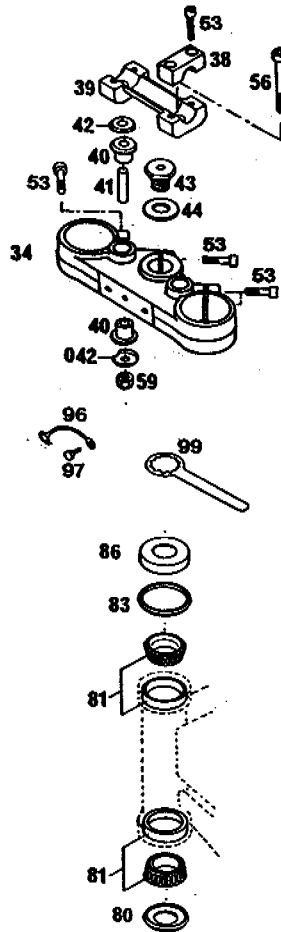
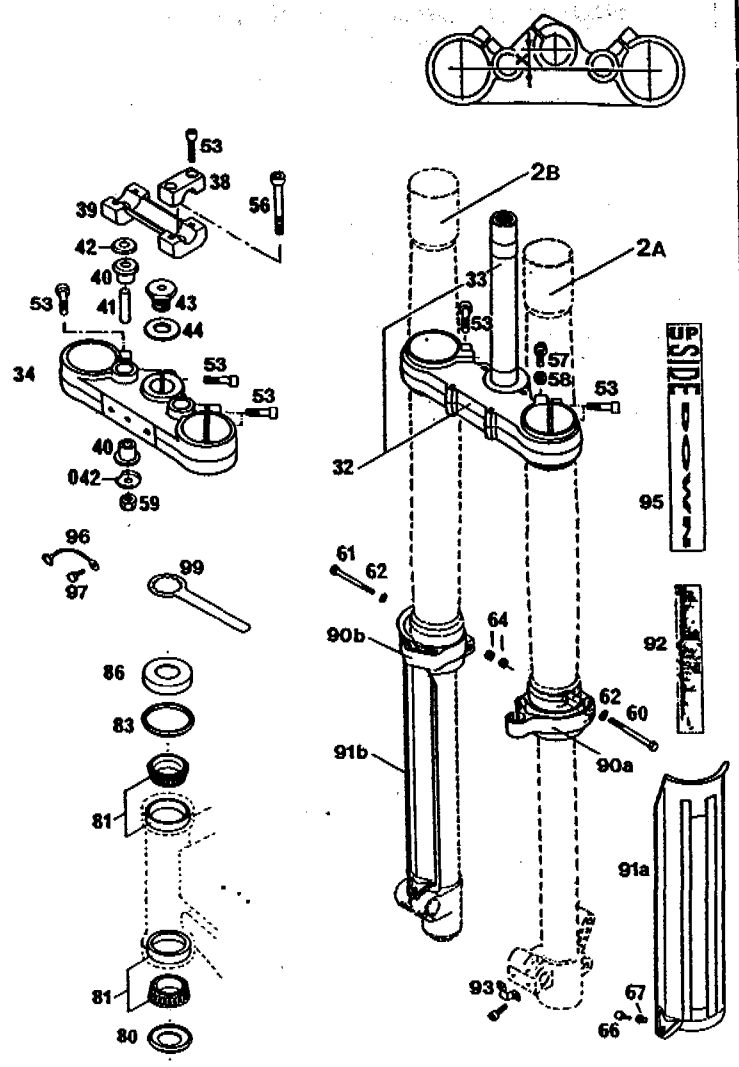

93-500.01.1

GABELBEINE WP 125-550 '93
FRONT FORK LEGS

BILD FIG.	TEILENUMMER PART NUMBER	BEZEICHNUNG DESCRIPTION	STK. QTY.
1	545.01.038.000	STELCKNOPF-ZUGSTUFE ADJUSTABLE KNOB	2
2	545.01.039.000	O-RING 12X3 O-RING	2
3	545.01.036.000	VERSCHLUßSCHRAUBE M 49 X 1,5 SCREW CAP	2
4	0770 430030	O-RING 43 X 3 O-RING	2
5	545.01.051.000	GUMMI-DICHTUNG 14, 1X 22 X 4 RUBBER RING	2
6	545.01.050.000	HALBMOND KEIL KEY	4
7	545.01.052.000	BÜCHSE 47X21 BUSHING	2
9*	502.01.404.500	AUSSENROHR 54/57X606 OUTER TUBE	'93 2
10	545.01.026.300	FÜHRUNGSBÜCHSE UNTEN GUIDE BUSH LOWER	2
11	564.01.027.000	RING 42 X 49,2 X 1,5 RING	2
12	564.01.005.000	SIMMERRING 40 X 49,5 X 7 SEAL	2

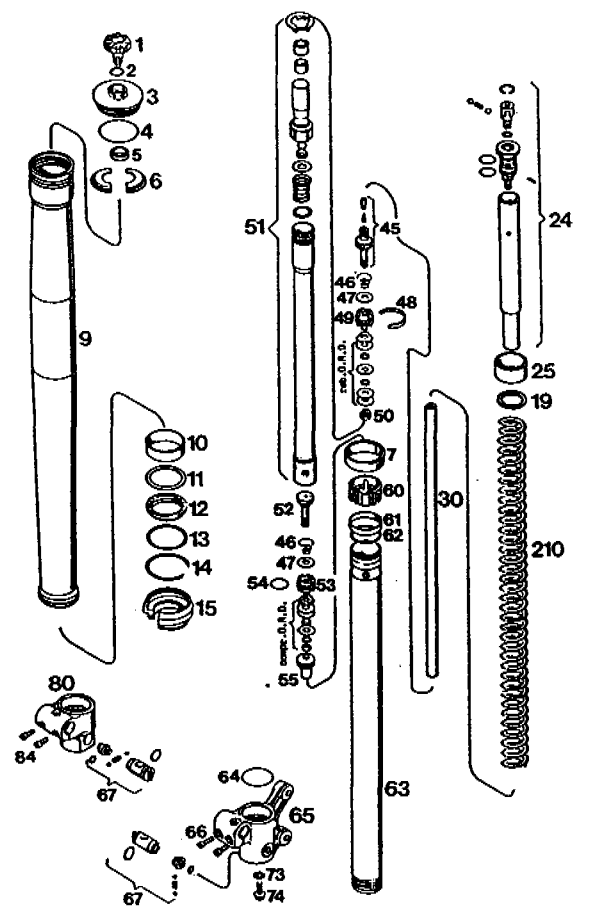

93-500.01.1

GABELBEINE WP 125-550 '93
FRONT FORK LEGS

BILD FIG.	TEILENUMMER PART NUMBER	BEZEICHUNG DESCRIPTION	STK. QTY.
13	564.01.127.000	RING 49,5 X 45 X 1 RING	2
14	564.01.029.000	SEGER-SPRENGRING SB50 CIRCLIP	2
15	564.01.025.100	STAUBMANSCHETTE D40 DUST SCRAPER	'91 2
19*	545.01.019.000	SCHEIBE 24,5 X 34 X 2 WASHER	2
24	545.01.057.044	HYDROSTOP KPL. L=227,5MM HYDROSTOP CPL	2
25	564.01.022.200	VORSPANNBÜCHSE H=2,5MM PRELOAD BUSH 2,5MM	2
25	564.01.022.000	VORSPANNBÜCHSE H=5MM PRELOAD BUSH	2
25	564.01.022.100	VORSPANNBÜCHSE H=10MM PRELOAD BUSH	2
30	545.01.010.000	SPINDEL 012 L=551MM SPINDLE	2
45	545.01.067.044	KEGEL-ZUGSTUFE KPL. TAPER REB.CPL.	2
46	545.01.068.000	FEDER SPRING	4
47	545.01.069.000	KONUSSCHEIBE 8X18X0,4 CONICAL WASHER	4
48	545.01.070.000	KOLBENRING 4 X 1 X 62 PISTON RING 4X1X62	2
49	545.01.071.000	KOLBEN ZUGSTUFE PISTON REB.	2
50	545.01.072.000	SECHSKANTMUTTER M6X0,5 HEX.NUT	2
51*	502.01.473.544	DÄMPFERROHR KPL. L=408MM DAMPING TUBE CPL.	'93 2
52	545.01.074.100	SPEZ.SCHRAUBE M6X0,5 D2 SPEC.SCREW	2
53	545.01.075.000	KOLBEN DRUCKSTUFE PISTON COMP.	2
54	0770 020160	O-RING 15,6 X 1,78 O-RING	2
55	545.01.076.000	KEGEL M22,3X1 -DRUCKSTUFE TAPER M 22,3X1	2
60	545.01.077.000	SPANNBÜCHSE BUSHING	2
61	545.01.045.300	LAGERRING 42,8 X 8 BEARING RING	2
62	545.01.046.000	RING 39X42X1 RING 39X42X1	2
63	545.01.003.300	INNENROHR L=625 FORK TUBE	'92 2
64	0770 380020	O-RING 38 X 2 O-RING 38X2	2
65	545.01.206.100	GABELFAUST LINKS D17 BREMBO AXLE CLAMP L/S	1
66	0912 070253	ISK-SCHRAUBE DIN912-M7X25 A H SCREW	2
67	545.01.078.144	STELLSCHRAUB.-DRUCKST.KPL. ADJUSTABLE KNOB CP	2
73	545.01.081.000	DICHTRING 8 X 12 X 1,5 SEAL RING	2



BILD FIG.	TEILENUMMER PART NUMBER	BEZEICHUNG DESCRIPTION	STK. QTY.
74	545.01.082.000	BUNDSCHRAUBE M8X20 SCREW M8X20	2
80	545.01.106.100	GABELFAUST RECHTS D21 AXLE CLAMP R/S	1
84	0912 070253	ISK-SCHRAUBE DIN912-M7X25 A H SCREW	2
210	545.01.021.380	FEDER 530 MM / 3,8 KG SPRING K1MS93, K1GE93	2
210	545.01.021.405	FEDER 530 MM / 4,0 KG SPRING K2M93, K23E93, K23G93	2
210	545.01.021.420	FEDER 530 MM / 4,2 KG SPRING K235SCM93	2
210	545.01.021.440	FEDER 530 MM / 4,4 KG FORK SPRING	X
210	545.01.021.460	FEDER 530MM / 4,6 KG FORK SPRING	X

* = NEUTEILE / NEW PARTS.

X = NACH BEDARF / AS REQUIRED

93-565.01.1 GABELBEINE WP 500 SX '93
FRONT FORK LEGS

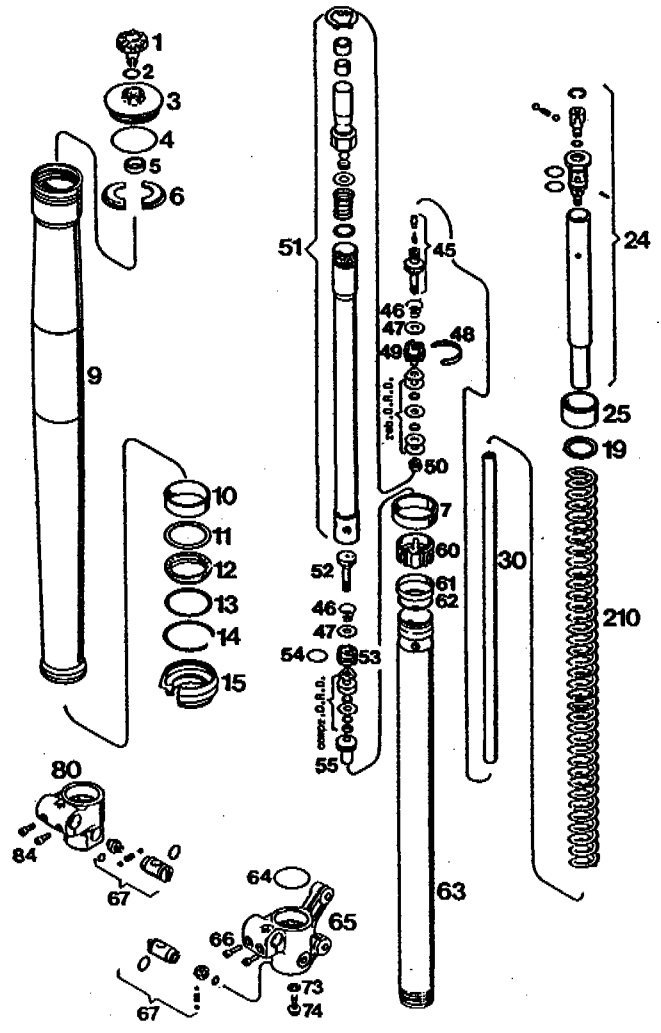
BILD FIG.	TEILENUMMER PART NUMBER	BEZEICHUNG DESCRIPTION	STK. QTY.
3*	576.01.036.044 565.01.490.244	VERSCHLUSSKAPPE KPL. IBS '93 CREW CAP CPL.	2
4	0770 430030	O-RING 43 X 3	2
5	545.01.051.000	O-RING	2
6*	545.01.050.000 565.01.450.200	GUMMI-DICHTUNG 14, 1X 22 X 4 RUBBER RING	2
9*	502.01.404.500	HALBMONDKEIL IBS KEY	4
10	545.01.026.300	AUSSENROHR 57/57X606 OUTER TUBE	'93 2
11	564.01.027.000	FÜHRUNGSBÜCHSE UNTEN GUIDE BUSH LOWER	2
12	564.01.005.000	RING 42 X 49,2 X 1,5 RING	2
13	564.01.127.000	SIMMERRING 40 X 49,5 X 7 SEAL	2
14	564.01.029.000	RING 49,5 X 45 X 1 RING	2
15	564.01.025.100	SEEGER-SPRENGRING S850 CIRCLIP	2
19*	545.01.019.000	STAUBMANSCHETTE D40 DUST SCRAPER	'91 2
24*	565.01.457.244	SCHEIBE 24,5 X 34 X 2 WASHER	2
25	564.01.022.200	HYDROSTOP KPL. L=227,5MM IBS HYDROSTOP CPL IBS	2
25	564.01.022.000	VORSPANNBÜCHSE H=2,5MM PRELOAD BUSH 2,5MM	2
25	564.01.022.100	VORSPANNBÜCHSE H=5MM PRELOAD BUSH	2
25	564.01.022.100	VORSPANNBÜCHSE H=10MM PRELOAD BUSH	2
48	545.01.070.000	KOLBENRING 4 X 1 X 62 PISTON RING 4X1X62	2
49*	565.01.471.244	ZUGSTUFENDÄMPFUNG KPL. IBS '93 REBOUND DAMP. CPL	2
50	545.01.072.000	BAK593MX SECHSKANTMUTTER M6X0,5 HEX.NUT	2
54	0770 020160	O-RING 15,6 X 1,78 O-RING	2
55*	565.01.476.244	DRUCKSTUFENDÄMPFUNG KPL. IBS93 COMPRESS. DAMP. CPL	2
56*	565.01.467.244	BAK593MX EINSTELLSCHRAUBE KPL. IBS '93 ADJUSTING SCREW	2
60	545.01.077.000	SPANNBÜCHSE BUSHING	2
61	545.01.045.300	LAGERRING 42,8 X 8 BEARING RING	2
62	545.01.046.000	RING 39 X 42 X 1 RING	2
63	545.01.003.300	INNENROHR L=625 FORK TUBE	'92 2
64	0770 380020	O-RING 38 X 2 O-RING 38X2	2
65	545.01.206.100	GABELFAUST LINKS D17 BREMBO AXLE CLAMP L/S	1



BILD FIG.	TEILENUMMER PART NUMBER	BEZEICHUNG DESCRIPTION	STK. QTY.
66	0912 070253	ISK-SCHRAUBE DIN912-M7X25 A H SCREW	4
67	545.01.078.144	STELLSCHRAUB.-DRUCKST.KPL. ADJUSTABLE KNOB CP	2
73	545.01.081.000	DICHRING 8 X 12 X 1,5 SEAL RING	2
74	545.01.082.000	BUNDSCHRAUBE M8X20 SCREW M8X20	2
80	545.01.106.100	GABELFAUST RECHTS D21 AXLE CLAMP R/S	1
210	545.01.021.380	FEDER 530 MM / 3,8 KG SPRING	X
210	545.01.021.405	FEDER 530 MM / 4,0 KG SPRING	X
210	545.01.021.420	FEDER 530 MM / 4,2 KG SPRING	2
210	545.01.021.440	FEDER 530 MM / 4,4 KG FORK SPRING	X
210	545.01.021.460	FEDER 530MM / 4,6 KG FORK SPRING	X

* = NEUTEILE / NEW PARTS X = NACH BEDARF / AS REQUIRED

LENKER, ARMATUREN / HANDLEBAR, CONTROLS

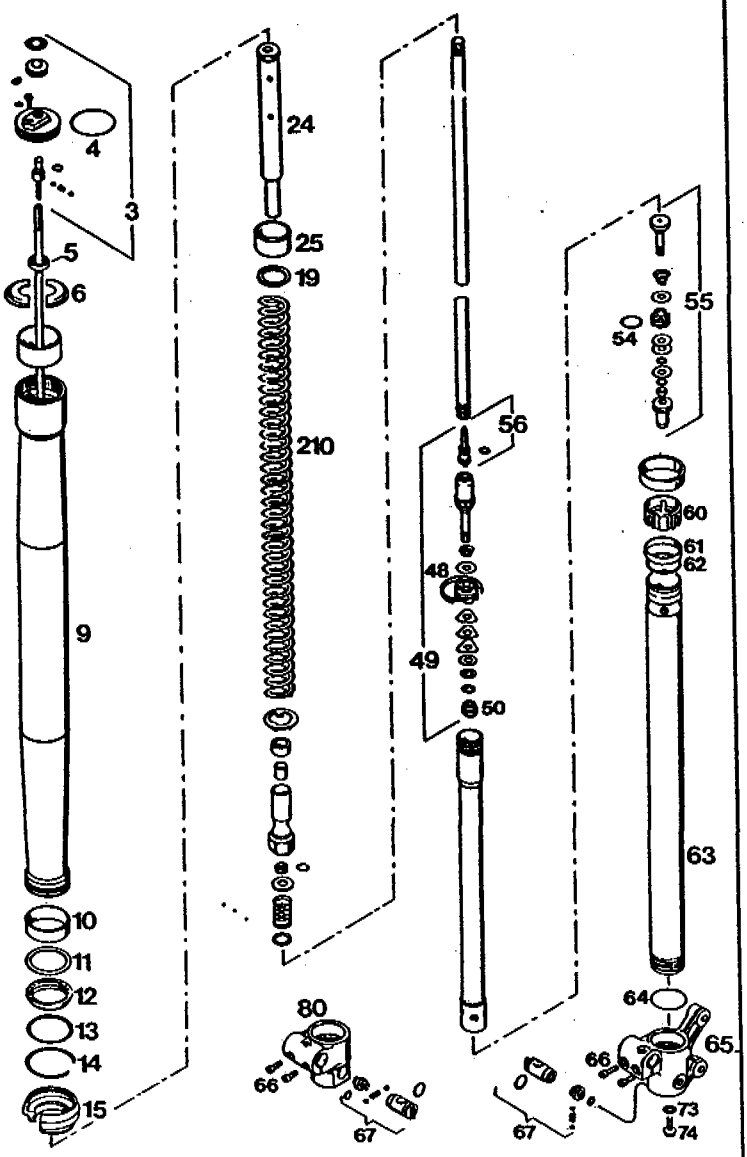
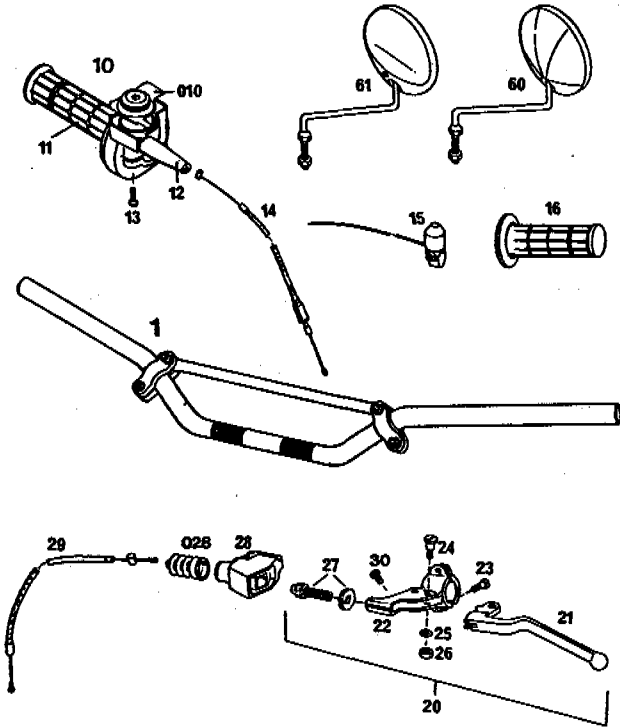

92-500.02.0

Bild Fig.	Teilenummer Part number	Stk. Qty.	Bild Fig.	Teilenummer Part number	Stk. Qty.
1	565.02.001.144	1	21	565.02.055.000	1
10	580.02.010.000	1		500/550	
010	580.02.011.000	1	22	546.02.023.000	1
11	565.02.003.000	1		125/250/300	
12	540.02.016.000	1	22	542.02.023.000	1
13	0084 050203	2		500/550	
14	502.02.091.500	1	23	0964 050163	2
	125		24	510.02.028.000	1
	VHSB 37		25	0125 060003	1
14	502.02.091.000	X	26	0934 060003	1
	125 PHSB35		27	510.02.024.000	1
14	546.02.091.000	1	28	546.02.026.000	1
	250/300		28	546.02.026.000	1
	KEIHIN		028	546.02.126.000	1
14	565.02.091.100	1	29	530.02.090.000	1
	500 SX, 550 MXC,			125	
	KEIHIN		29	546.02.090.000	1
15	510.11.198.000	1		250/300	
16	565.02.052.000	1	29	565.02.090.000	1
20	502.02.040.000	1		500/550	
	125/250/300		30	546.02.029.000	1
20	565.02.040.000	1		125/250/300	
	500/550		60	120.12.025.100	1
21	502.02.055.000	1	61	544.12.025.028	1
	125/250/300				

X = NACH BEDARF / AS REQUIRED

HANDBREMSZYLINDER / HANDBRAKE CYLINDER

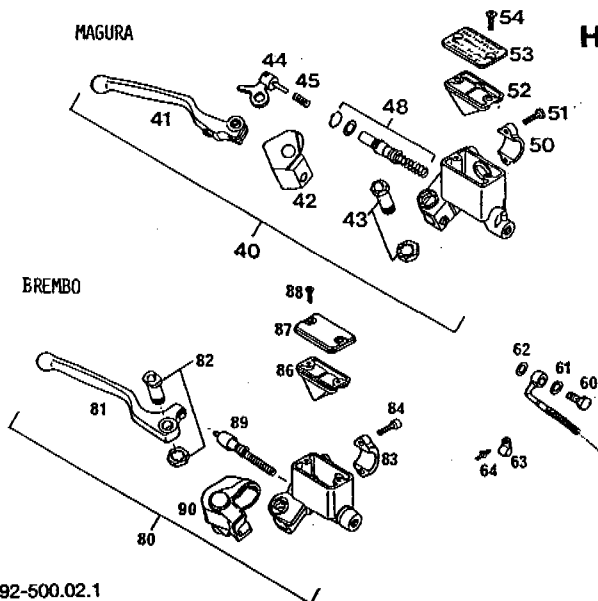

92-500.02.1

Bild Fig.	Teilenummer Part number	Stk. Qty.	Bild Fig.	Teilenummer Part number	Stk. Qty.
40	565.13.001.744	1	62	420.13.026.000	1
	Ø 11			10x16x1,5	
41	565.13.020.700	1	63	570.13.070.100	1
42	565.13.026.500	1	64	570.13.071.000	1
43	565.13.015.500	1	80	545.13.001.044	1
44	565.13.051.500	1	81	544.13.020.000	1
45	565.13.052.500	1	82	544.13.015.000	1
48	565.13.050.500	1	83	544.13.011.000	1
	Ø 11		84	0912 060203	2
50	565.13.011.500	1	86	544.13.009.000	1
51	0084 060203	2	87	544.13.012.000	1
52	565.13.009.500	1	88	0965 040123	2
53	565.13.012.500	1	89	544.13.050.100	1
54	0965 050163	2	90	544.13.026.000	1
60	502.13.025.000	1			
61	420.12.226.000	1			
	10x16x1				

X = NACH BEDARF / AS REQUIRED

RAHMEN / FRAME

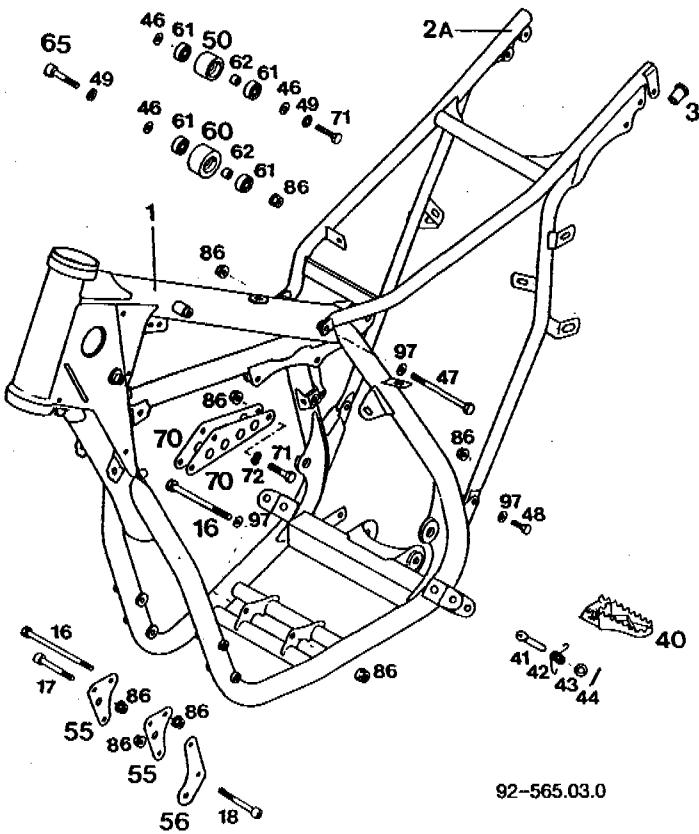

92-565.03.0

Bild Fig	Teilenummer Part number	Stk Qty	Bild Fig	Teilenummer Part number	Stk Qty
1▲	565.03.001.800 49	1	46	502.03.028.000	X
2a▲	565.03.002.600 49	1	47	0931 080903	1
			48	0933 080203	2
			49	360.03.014.000	X
			50	502.03.053.000	1
3	550.03.080.000	2	55	565.03.055.000	2
			56	565.05.073.000	1
16	0931 081103	2	60	502.03.053.100	1
17	0912 080503	2	61	0625 006087	4
18	0912 080553	2	62	740.03.021.000	2
40▲	546.03.040.000 49	1	65	0931 080353	1
	L/S		70	545.03.045.000	2
	-▲ 546.03.140.000 49	1	71	0933 080303	4
	R/S		72	0137 080000	X
41	546.03.044.000	2	86	543.10.086.000	11
42	546.03.041.000	2	97	0125 080003	3
43	0125 100003	2			
44	0094 032253	2			

x= NACH BEDARF/AS REQUIRED

**FUSSBREMSBETÄTIGUNG
REAR BRAKE CONTROL**

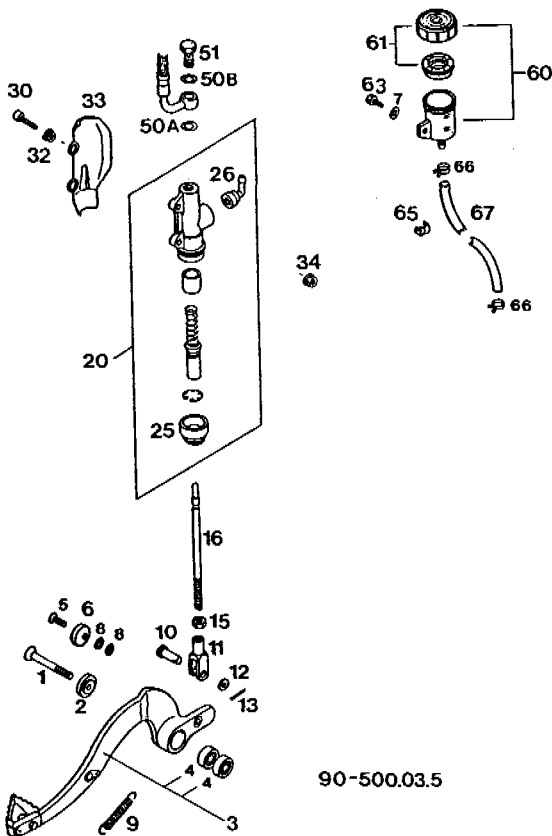

90-500.03.5

Bild Fig	Teilenummer Part number	Stk Qty	Bild Fig	Teilenummer Part number	Stk Qty
1	0991 080403	1	30	0912 060253	2
2	565.03.061.300	1	31	0797 060003	2
3	502.03.060.544	1	32	502.13.161.000	2
4	0625 006087	2	33	545.13.038.000	1
5	0991 060163	1	34	565.09.064.000	2
6	502.03.063.000	1	50a	420.13.226.000	1
7	0125 060003	1		10x16x1	
8	0797 060003	2	50b	420.13.026.000	1
9	545.03.062.000	1		10x16x1,5	
10	580.03.067.000	1	51	502.13.025.000	1
11	580.03.069.000	1	60	545.13.030.044	1
12	502.03.028.000	1	61	545.13.031.044	1
13	0094 020203	1	63	0933 060163	1
15	0934 080003	1	65	550.11.022.100	1
16	545.03.068.000	1	66	580.07.017.000	2
20	545.13.101.044	1	67	580.07.016.001	0,25 m
25	545.13.151.000	1			
26	545.13.155.000	1			

SCHWINGARM / SWINGARM



Bild Fig.	Teilenummer Part number	Stk. Qty.	Bild Fig.	Teilenummer Part number	Stk. Qty.
6	400.06.006.000	X	41	502.03.097.000	4
12	502.03.014.100	1	42	546.03.036.000	2
13	502.30.011.000	1	43	0760 253270	4
14	502.30.211.000	1	44	546.03.090.000	4
15	0985 141503	1	60	502.07.060.000	1
17	0991 080353	1	63	0963 060163	X
18	543.10.086.000	1	64	544.07.064.000	1
19	0991 060753	2	66	565.07.066.000	1
21	510.03.021.000	2	68	502.07.068.000	1
23▲	545.03.023.100491	1	69	0125 060003	X
24	510.07.069.100	1	70	580.07.070.500	1
25	571.03.225.000	1	71	722.10.079.000	2
26▲	502.03.026.100491	1	72	501.07.072.000	1
28	0933 080253	1	072	543.07.072.000	1
29	0934 080003	1	73	502.07.073.000	1
30	502.03.030.800	1	74	0912 060123	2
	125 L=560		75a	0931 060503	1
30	565.03.030.600	1	75b	0931 060553	1
	500/550 L=580		075	0963 060553	2
030	502.03.030.844	1	76	0933 060203	X
	125		77	565.09.064.000	2
030	565.03.030.644	1	78	0797 060003	X
	500/550		79	0021 060003	X
38	546.11.076.000	2	80	0985 060003	X
39	0985 050103	2			
40	502.03.081.700	2	90▲	502.03.429.000	2

X = NACH BEDARF / AS REQUIRED

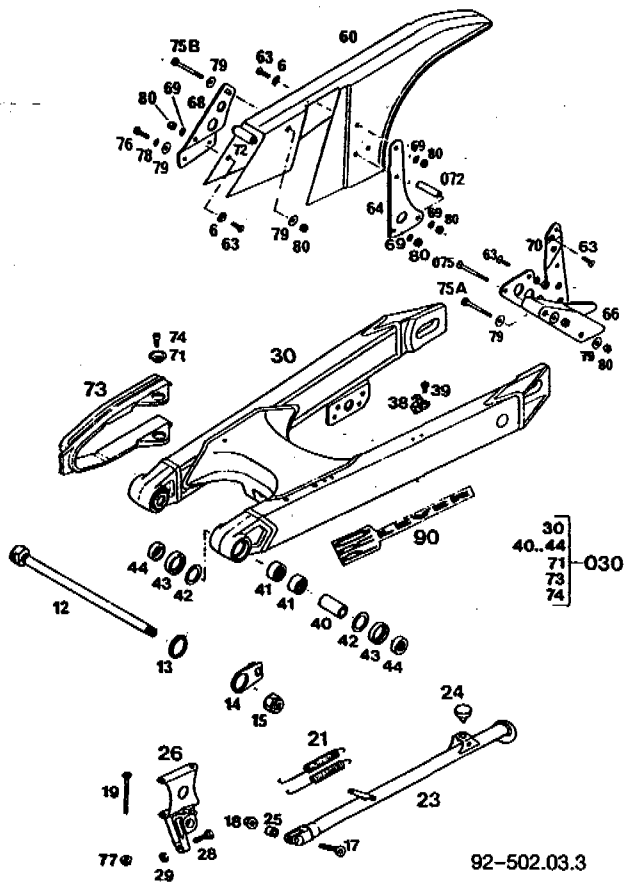
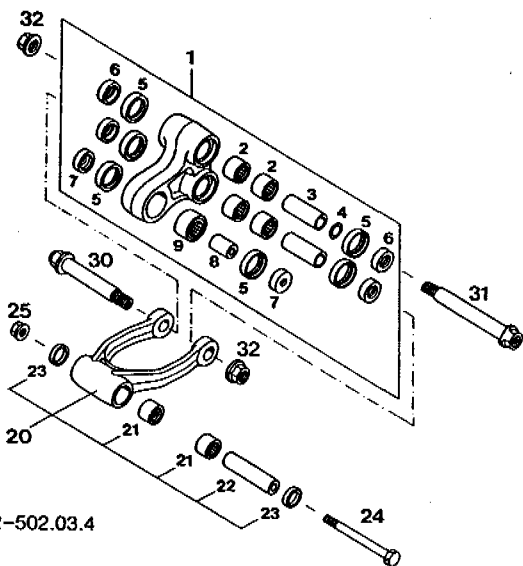

PRO-LEVER ANLENKUNG PRO-LEVER SYSTEM

Bild Fig.	Teilenummer Part number	Stk. Qty.	Bild Fig.	Teilenummer Part number	Stk. Qty.
1	546.03.080.044	1	8	546.03.086.000	1
2	546.03.097.000	4	9	546.03.197.000	1
3	546.03.081.000	2	20	502.03.083.144	1
4	546.03.090.010	X		126 mm	
	15,2x19x0,1		21▲	565.03.195.000	2
4	546.03.090.020	X	22	546.03.084.000	1
	15,2x19x0,2		23	0760 182442	2
4	546.03.090.030	X	24	546.03.087.000	1
	15,2x19x0,3		25	490.09.082.000	1
5	0760 253270	6	30	546.03.182.050	1
6	546.03.090.000	4	31	502.03.082.150	1
7	546.03.085.000	2	32	546.03.015.000	2

92-502.03.4

FEDERBEIN / SHOCK ABSORBER



Bild Fig.	Teilenummer Part number	Stk. Qty.
9a	542.04.109.000	1
9b	542.04.009.000	1
10a▲	565.04.410.000 BAK5M93 500 SX	1
10a▲	565.04.210.000 K5MC93 550 MXC	1
11	501.04.011.046 46-280	1
11	501.04.011.048 48-280	1
11	501.04.011.050 50-280	1
11	501.04.011.052 52-280	1
11	501.04.011.054 54-280	1
16	544.04.016.000	1
20	542.04.020.100	1
21	565.03.086.000	1
22	543.10.086.100	1
25	565.03.093.000	1
26	0125 100003	1
124	543.12.024.000	2

AUSPUFF / EXHAUST PIPE

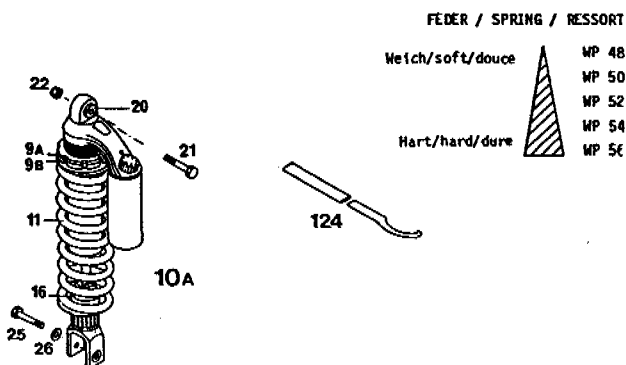

Bild Fig	Teilenummer Part number	Stk Qty	Bild Fig	Teilenummer Part number	Stk Qty
1	565.05.070.500 500/550	1	10	432.05.262.000 30x15	1
5	0933 080163	2	10	510.05.062.100 30x20	1
6	0797 080003	4	11	510.05.063.000	3
7	0125 080003	4	12	543.05.058.000	2
8	0934 080003	2	13	543.05.057.000	1
9	510.05.067.000	2			

AUSPUFF SCHALLDÄMPFER EXHAUST SILENCER

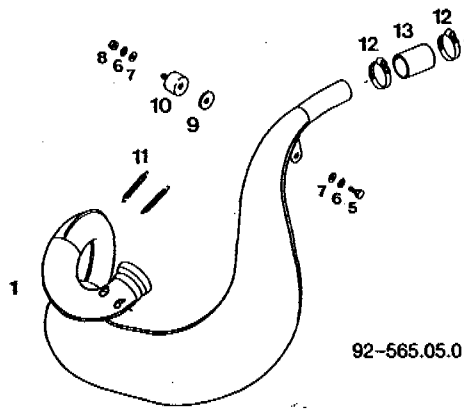

Bild Fig	Teilenummer Part number	Stk Qty	Bild Fig	Teilenummer Part number	Stk Qty
10▲	565.05.079.50022	1	54b	543.05.065.144	1
15	580.05.078.070	1	55	543.05.068.000	1
	70 g		56	0933 060163	1
15	580.05.078.280	1	57	0125 060003	1
	280 g		60	0933 080163	1
16	0009 040083	4	61	0797 080003	2
17	0009 050103	6	62	0125 080003	2
50	0931 060303	1	63	0934 080003	1
51	0021 060003	1	65	510.05.062.100 30x20	1
52	543.05.069.000	1	66	510.05.067.000	1
53	565.09.064.000	1			

FILTERKASTEN / AIR FILTER BOX

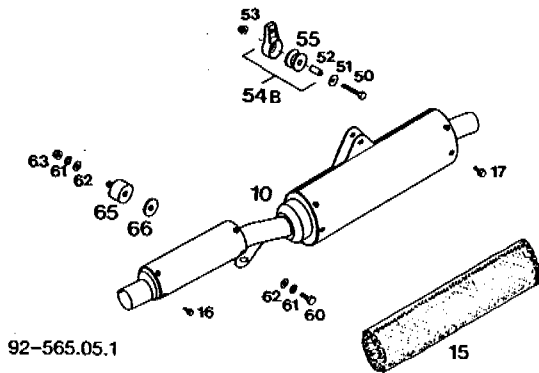

Bild Fig	Teilenummer Part number	Stk Qty	Bild Fig	Teilenummer Part number	Stk Qty
1	545.06.001.100 MX	1	14	560.03.076.000	1
1	545.06.501.100 ENDURO	1	20	550.06.028.000	1
4a	545.06.002.000	1	21	565.06.026.200	1
4b	545.06.502.050	1	22	545.06.028.000	1
4c	545.06.502.051	1	25	432.06.043.000	2
5	545.06.002.052	1	26	0933 060163	1
10	501.06.016.000	1	27	0021 060003	3
11	565.06.015.000	1	28	0985 060003	3
12	510.05.067.000	1	30	502.06.010.000	1
13	510.06.097.000	1	32	572.06.004.044	4
			33	545.06.006.000	4

93-565.07.0

TANK, SITZBANK, VERKL. 500/550'93
TANK, SEAT, S. COVERS

BILD FIG.	TEILENUMMER PART NUMBER	BEZEICHUNG DESCRIPTION	STK. QTY.
3*	565.07.403.200	KLEBEFOLIE SPOILER LI. 500'93 DECAL SPOILER L/S	1
-*	565.07.503.200	KLEBEFOLIE SPOILER RE. 500'93 DECAL SPOILER R/S	1
5	550.07.005.200	BENZINHAWN KPL. "OFF-ON-RES" GAS TAP CPL. R/S	1
5	550.07.005.300	BENZINHAWN KPL. "OFF-ON" GAS TAP CPL.	1
6	550.07.006.200	DICHTUNG GASKET	1
7	310.07.007.001	SCHLAUCH 5 X 8 PER METER BREATHER HOSE 5X8	0,32
8	560.07.008.144	TANKVERSCHLUSS GAS CAP CPL	1
9	560.07.009.100	DICHTUNG GASKET	1
10	510.05.067.000	ASBESTSCHEIBE 8,5X28X3 GASKET WASHER	1
13	565.07.013.500	BENZINTANK 500/550 '92 GASTANK	1
15	501.07.015.000	TANKGUMMI 35X16 FR.MOUNT GASTANK	2
16	580.07.016.001	BENZINSCHLAUCH AUS GUMMI 6X1,5 FUEL LINE	0,28
016	580.07.117.000	KLAMMER F.BENZINSCHLAUCH 10MM CLAMP	2
17	0912 080163	ISK-SCHRAUBE DIN912-M8X16 A H SCREW	2
18	0676 550223	SK-BLECHSCHR. DIN7676-B5,5X22 SCREW	2
19	0797 050003	ZAHNSCHEIBE DIN6797-J5,3 LOCK WASHER	2
20	0912 080353	ISK-SCHRAUBE DIN912-M8X35 A H SCREW	1
21	0021 080003	SCHEIBE DIN9021-A8,4 FLAT WASHER	1
23	571.03.225.000	BÜCHSE 8,2X12X10 BUSHING	1
24	580.07.044.000 545.07.011.000	LINSENSCHRAUBE M6X16 LENTIL HEAD SCREW	1
28	565.35.028.500	SPOILER LINKS 500/550 '92 SPOILER L/S	1
--	565.35.029.500	SPOILER RECHTS 500/550 '92 SPOILER R/S	1
30	546.35.039.000	BUNDSCHRAUBE M6X15 SW=8 FLANGE BOLT	8
40*	565.07.040.600	SITZBANK VIOLETT 500/550'93 SEAT	1
040*	565.07.040.650	SITZBANKÜBERZUG VIOLETT 500'93 SEAT COVER VIOLET	1
41	580.07.041.000	HALTEWINKEL F.SITZBANK SEAT BRACKET	2
42	0965 060163	SENKSCHRAUBE DIN965-M6X16 COUNTERSUNK SCREW	4
43	0912 080203	ISK-SCHRAUBE DIN912-M8X20 ALLEN HEAD SCREW	2
44	0797 080003	ZAHNSCHEIBE DIN6797-J8,4 LOCK WASHER	2

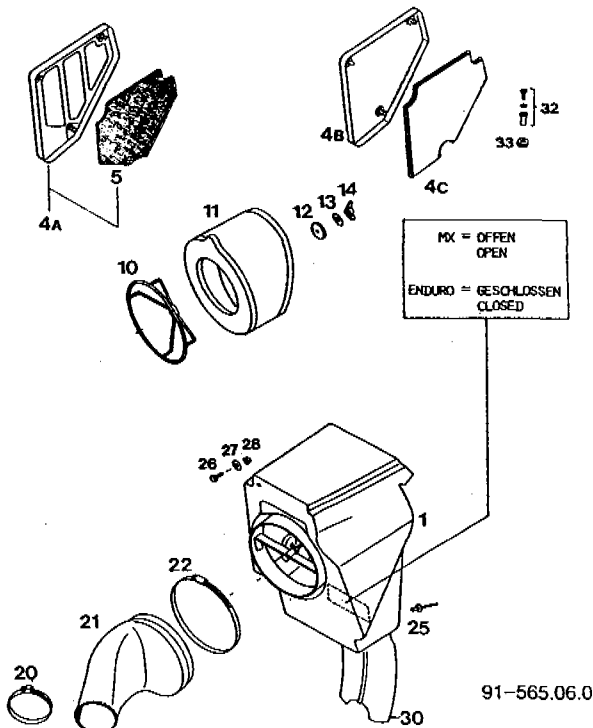

BILD FIG.	TEILENUMMER PART NUMBER	BEZEICHUNG DESCRIPTION	STK. QTY.
45	140.04.030.000	SCHEIBE 8,4X20X2,5 WASHER	2
95	565.08.041.500	SEITENVERKLEIDUNG LINKS '92 SIDE COVER L/S	1
--	502.08.075.000	SEITENVERKLEIDUNG RECHTS SIDE COVER R/S	1
96	502.08.096.080	KLEBEFOLIE LINKS GELB '87 DECAL L/S YELLOW	1
--	502.08.196.080	KLEBEFOLIE RECHTS GELB '87 DECAL R/S YELLOW	1
--*	565.01.499.080	GAR.STARTNUMMERNFELDER GELB '93 DECAL SET YELLOW	1
97	542.08.042.000	GUMMITÖLLE RUBBER SLEEVE	3
98	543.08.043.002	FEDERSTECKER 2 MM SPRING CLIP	2
99	546.35.039.000	BUNDSCHRAUBE M6X15 SW=8 FLANGE BOLT	1
100	502.35.033.300	KLIPS-MÜTTERNHALTER M6 KP142 SNAP NUT	1
101	543.08.042.000	GUMMIPUFFER RUBBER	X

* = NEUTEILE / NEW PARTS

X = NACH BEDARF / AS REQUIRED

BILD FIG.	TEILENUMMER PART NUMBER	BEZEICHNUNG DESCRIPTION	STK. QTY.
1	545.07.013.100	BENZINTANK 500/550 12 LITER GASTANK 12 L	1
2*	565.07.402.000	KLEBEFOLIE TANK "KTM" 550 '93 DECAL "KTM"	2
3*	565.07.403.300	KLEBEFOLIE TANK LINKS 550 '93 DECAL GASTANK L/S	1
-4	565.07.503.300	KLEBEFOLIE TANK RECHTS 550 '93 DECAL GASTANK R/S	1
5*	545.07.012.000/19	STÜTZE FÜR TANK 12 L BRACKET	'93 1
6	545.07.012.050	SCHUTZKAPPE RUBBER CAP	2
7	0933 060123	SK-SCHRAUBE DIN933-M6X12 H H SCREW	2
8	0797 060003	ZAHNSCHEIBE DIN6797-J6,4 LOCK WASHER	2
9	0125 060003	SCHEIBE DIN125-A6,4 FLAT WASHER	2
10	565.08.041.600	SITENVERKLEIDUNG LINKS '92 SIDE COVER L/S	1
--	502.08.075.000	SEITENVERKLEIDUNG RECHTS SIDE COVER R/S	1
90*	565.08.496.100	KLEBEFOLIE "MXC" LINKS 550'93 DECAL "MXC" L/S	1
91*	565.08.596.100	KLEBEFOLIE "MXC" RECHTS 550'93 DECAL "MXC" R/S	1
92*	565.08.596.050	KLEBEFOLIE SETENVERKL.RE '93 DECAL S.COVER R/S	1
--*	565.01.499.080	GAR.STARTNUMMERNFELDER GELB'93 DECAL SET YELLOW	1

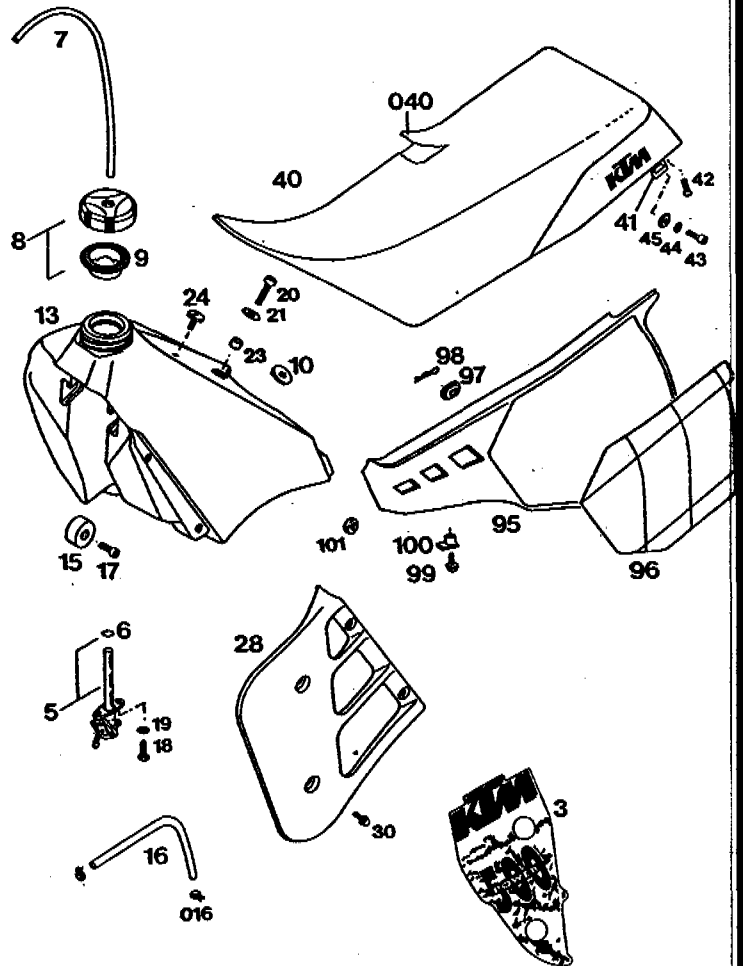
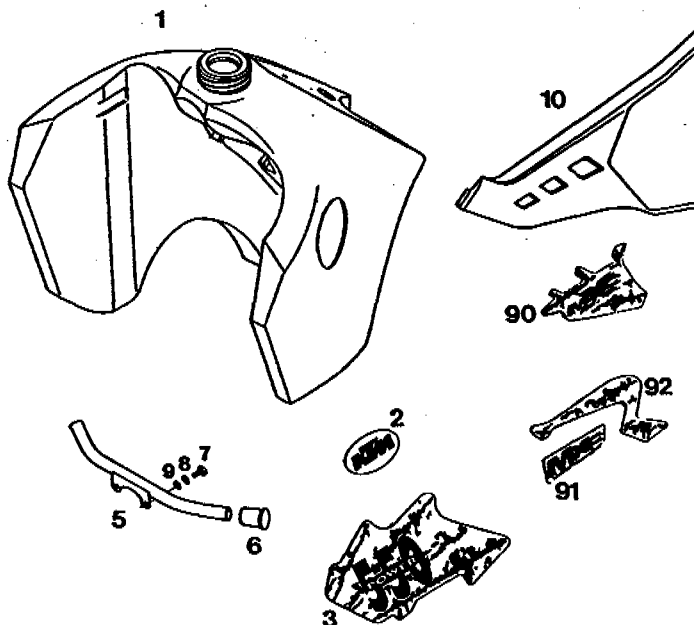

93-565.08.0

**KOTFLÜGEL 500/550 '93
FENDERS**

BILD FIG.	TEILENUMMER PART NUMBER	BEZEICHNUNG DESCRIPTION	STK. QTY.
5	0966 050163	LINSENKNSCHR. DIN966-M5X16 COUNTERSUNK SCREW	1
6	400.06.006.000	FASONSCHIEBE 6MM WASHER	1
7	0021 050003	SCHEIBE DIN9021-A5,3 FLAT WASHER	1
8	0985 050003	SS-MUTTER DIN985-M5 S L NUT	1
10*	502.08.410.000	VORDERRADKOTFLÜGEL FRONT FENDER	'93 1
12	545.01.092.100	TACHOWELLENABWEISER SP.CABLE REFUSER	'91 1
13	546.01.093.000	KABELFÜHRUNG KPL. CABLE GUIDE CPL.	1
19*	546.08.019.100	SEILFÜHRUNG CABLE GUIDE	'93 1
20*	502.08.020.000	DISTANZBÜCHSE 7 X 10 X 7,5 SPACER BUSHING	4
40	502.08.014.000	KOTFLÜGEL HINTEN MX'87 REAR FENDER	1
45	0931 060403	SK-SCHRAUBE DIN931-M6X40 H H SCREW	1
46	0021 060003	SCHEIBE DIN9021-A6,4 FLAT WASHER	X
47	120.11.016.000	SCHEIBE 6X12X3 WASHER	1
48	0985 060003	SS-MUTTER DIN985-M6 S L NUT	2
49	0933 060253	SK-SCHRAUBE DIN933-M6X25 H H SCREW	2
90*	502.08.490.000	KLEBEFOLIE VR-KOTFLÜGEL DECAL FRONT FENDER	'93 1
91*	502.08.491.000	KLEBEFOLIE HR-KOTFLÜGEL DECAL REAR FENDER	'93 1
92*	502.08.492.000	KLEBEFOLIE "KTM" MAGENTA DECAL "KTM"	'93 1
95*	502.01.495.000	START-NUMMERTAFEL VORNE FRONT NUMBER PLATE	'93 1
96*	502.01.496.500	KLEBEFOLIE "POWER 500" DECAL	'93 1
97*	502.01.496.550	KLEBEFOLIE "POWER 550" DECAL	'93 1
98*	565.01.499.080	GAR.STARTNUMMERNFELDER GELB'93 DECAL SET YELLOW	X

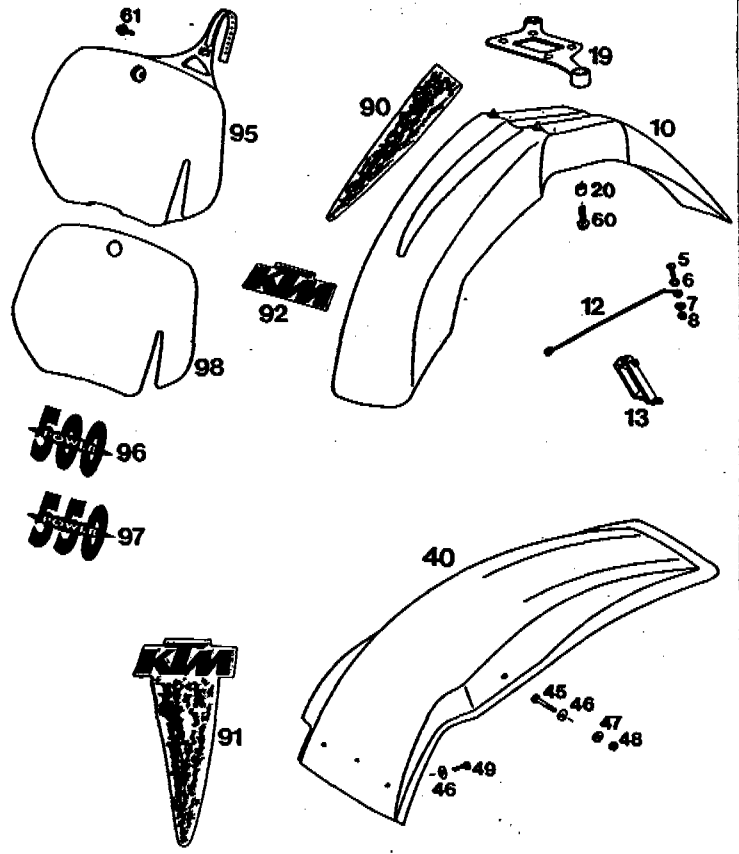

* = NEUTEILE / NEW PARTS

X = NACH BEDARF / AS REQUIRED

93-502.09.0 VORDERRAD 125-550 SX, MXC '93
FRONT WHEEL

BILD FIG.	TEILENUMMER PART NUMBER	BEZEICHNUNG DESCRIPTION	STK. QTY.
1*	546.09.001.444/90	VORDERRAD 1.6X21" DID FRONT WHEEL DID	1
1*	546.09.001.344/90	VORDERRAD 1,6X21" EXCEL FRONT WHEEL EXCEL	1
2*	546.09.010.144/90	VORDERRADNABE KPL SILBER SX'93 FRONT HUB	1
3	565.09.011.400	LAGERDISTANZROHR 17,5X22X82 SPACER TUBE	1
4	0625 060037	RILLENKUGELLAGER 6003 RSR C3 BEARING	2
6	0760 253571	WELLENDICHRING 25X35X7 DF SEAL RING	1
7	546.09.051.000	DISTANZRING L=7,5MM ALU SPACER	1
8	580.09.052.500	BUNDBÜCHSE L=15MM SPACER	'90 1
10	546.09.071.100	SPEICHE M5 X 234,5 MM 165 GRAD SPOKE	36
11	565.09.072.000	STAHLNIPPEL M 5 NIPPLE M5	36
12	546.09.070.200	FELGE VORNE 1,6 X 21" DID FRONT RIM	1
12	546.09.070.100	FELGE VORNE 1,6 X 21" EXCEL FRONT RIM	1
13	510.09.073.000	FELGENBAND 21" RIM BAND	1
14	510.09.075.000	SCHLAUCH 3.00/ 90/90-21" TUBE	1
14	545.09.075.000	VR-SCHLAUCH 80/100-21" TUBE	1
15	546.09.074.400	REIFEN 90/90-21"54R UNICROSS TYRE 90/90-21 UNIC	1
15	546.09.074.300	REIFEN 80/100-21" 51M D 701 TYRE	1
16	510.09.100.100	REIFENHALTER VM1 RIM LOCK	1
20	565.09.060.700	BREMSSCHEIBE VORNE D=260MM '92 BRAKE DISC	1
21	0912 060166	ISK-SCHRAUBE DIN6912-M6X16 A H SCREW	6
22	565.09.064.000	STOVER-FLANSCHMUTTER M6 SELF LOCKING NUT	6
30*	580.09.081.600	STECKACHSE 17MM L=208MM FRONT AXLE	1
32	490.32.011.000	SECHSKANTSCHRAUBE M10X20 H H SCREW	1

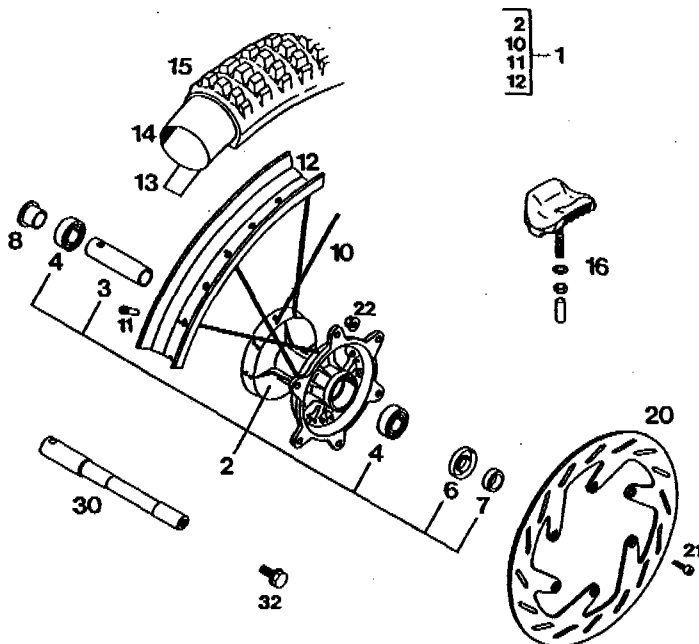

* = NEUTEILE / NEW PARTS

X = NACH BEDARF / AS REQUIRED

93-575.09.2

BREMSZANGE VORNE BREMBO 92
CALIPER FRONT

BILD FIG.	TEILENUMMER PART NUMBER	BEZEICHNUNG DESCRIPTION	STK. QTY.
1	546.13.201.044	BREMSZANGE VORNE KPL.2 KOLBEN CALIPER CPL.	1
5	546.13.205.000	REPARATURSATZ D=28MM REPAIR KIT	1
7	546.13.210.000	BOLZEN 6 X 45 BOLT	1
9	546.13.209.044	GARNITUR BREMSKLÖTZE FRENDQ222 BRAKE PAD SET	1
10	545.13.214.000	ENTLÜFTUNGSSCHRAUBE M10X1 BLEEDER SCREW	1
11	545.13.215.000	KAPPE F.ENTLÜFTUNGSSCHRAUBE DUST COVER	1
12	546.13.218.000	MANSCHETTENSATZ RUBBER SLEEVE SET	1
14	546.13.212.000	GARNITUR HALTEBLECHE RETAINING PLATES	1
15	0933 080303	SK-SCHRAUBE DIN933-M8X30 H H SCREW	2
16	0797 080003	ZAHNSCHEIBE DIN6797-J8,4 LOCK WASHER	2
17	0125 080003	SCHEIBE DIN125-A8,4 FLAT WASHER	2
21	502.13.029.500 545.13.029.000	BREMSSCHLAUCH 1655MM WP 4T'92 BRAKE HOSE 1635mm	1
30	420.13.226.000	DICHTRING 10 X 16 X 1 CU SEAL RING CU.	2
31	420.13.026.000	DICHTRING 10 X 16 X 1,5 CU SEAL RING CU.	1
35	502.13.025.000	HOHLSCHRAUBE M10X1X19 CONNECTING SCREW	1

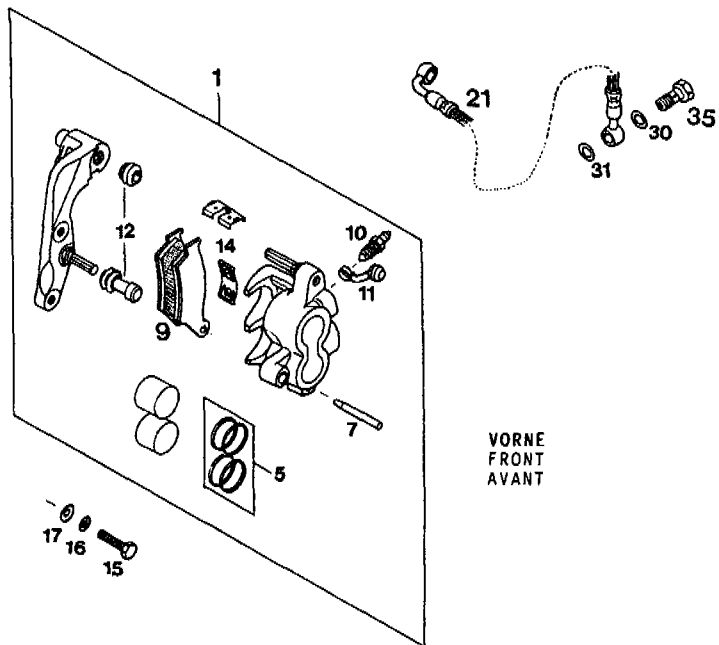

* = NEUTEILE / NEW PARTS

X = NACH BEDARF / AS REQUIRED

93-502.10.0 HINTERRAD 125/500/550 '93
REAR WHEEL

BILD FIG.	TEILENUMMER PART NUMBER	BEZEICHUNG DESCRIPTION	STK. QTY.
1*	502.10.001.944/90	HINTERRAD 2.15-19" EXCEL '93 REAR WHEEL 125 SX	1
1*	565.10.001.844/90	HINTERRAD 2.50-19" EXCEL '93 REAR WHEEL 500 SX	1
1*	502.10.201.944/90	HINTERRAD 2.15-18" DID '93 REAR WHEEL 125 ENDURO	1
1*	565.10.001.944/90	HINTERRAD 2.50-18" DID '93 REAR WHEEL 550 MXC	1
2*	546.10.010.044/90	HINTERRADNABE KPL. SILBER REAR WHEEL HUB KPL	1
3	565.10.011.000	LAGERDISTANZROHR 121,5 MM SPACER	1
4	0625 060058	RILLENKUGELLAGER 6005 2RS C3 BEARING	2
5	0760 324772	WELLENDICHTRING 32X47X7 TYP A SEAL	2
6	0472 047175	SEEGERRING DIN 472-47X1,75 CIRCLIP	1
7	546.10.016.000	BÜCHSE FÜR NABE BUSHING	2
8	546.10.071.000	SPEICHE M5X207-170G SPOKE 19"	18
8	565.10.171.600	SPEICHE M5X198-173G SPOKE 18"	18
9	502.10.071.700	SPEICHE M5X211-170G SPOKE 19"	18
9	502.10.171.000	SPEICHE M5X201-173G SPOKE 18"	18
10	546.10.070.100	FELGE HINTEN 2,15X19" EXCEL RIM	1
10	565.10.070.200	FELGE HINTEN 2,50-19" EXCEL RIM	1
10	546.10.070.300	FELGE HINTEN 2,15X18" DID RIM	1
10	565.10.070.300	FELGE HINTEN 2,50X18 DID RIM	1
11	565.09.072.000	STAHLNIPPEL M 5 NIPPLE M5	36
15*	580.10.060.600	BREMSSCHEIBE 220 MM ANGESENKT REAR BRAKE DISC	1
16	0984 060203	ISK-SCHRAUBE DIN6912-M6X20 HH SCREW	6
17	565.09.064.000	STOVER-FLANSCHMUTTER M6 SELF LOCKING NUT	6
20	546.10.051.045	KETTENRAD 45-Z SPROCKET 45 T	1
20	546.10.051.048	KETTENRAD 48-Z SPROCKET 48 T	1
20	546.10.051.050	KETTENRAD 50-Z SPROCKET 50 T.	1
20	546.10.051.052	KETTENRAD 52-Z SPROCKET 52 T.	X
21	545.10.052.000	KETTENRADSCHRAUBE-ISK M8X26 SPROCKET SCREW	6

* = NEUTEILE / NEW PARTS

X = NACH BEDARF / AS REQUIRED



BILD FIG.	TEILENUMMER PART NUMBER	BEZEICHUNG DESCRIPTION	STK. QTY.
22	543.10.086.000	STOVERFLANSCHMUTTER M8 GASKET WASHER	6
23	500.10.065.000	KETTE 5/8X1/4" CHAIN 5/8X1/4	1
23	500.10.065.001	KETTE 5/8X1/4" PER METER CHAIN 5/8X1/4 /M	X
24	500.10.066.000	KETTENSCHLOSS 5/8X1/4" MASTER LINK	1
23	530.10.065.001	O-RING KETTE 5/8X1/4 PER METER CHAIN /M	X
24	530.10.066.000	KETTENSCHLOSS 5/8X1/4" O-RING MASTER LINK	1
30	520.10.073.000	FELGENBAND 18"/19" RIM BAND	1
31	540.10.075.000	SCHLAUCH 4.00/4.50/120/130-18" TUBE	1
31	502.10.075.000	SCHLAUCH 100/90-19" TUBE	1
31	546.10.075.000	SCHLAUCH 110/90-19" TUBE	1
32	546.10.074.500	REIFEN 110/90-18"61M UNICROSS TYRE	1
32	546.10.074.600	REIFEN 130/90-18" 69M UNICROSS TYRE	1
32	502.10.074.400	REIFEN 120/90-18" 65R MCE TYRE	1
32	502.10.074.500	REIFEN 140/80-18" 70R MCE TYRE	1
32	502.10.074.300	REIFEN 100/90-19" 57M D 701 TYRE	1
32	546.10.074.300	REIFEN 110/90-19" D 701 TYRE	1

93-502.10.0

HINTERRAD 125/500/550 '93
REAR WHEEL

BILD FIG.	TEILENUMMER PART NUMBER	BEZEICHNUNG DESCRIPTION	STK. QTY.
33	540.10.100.100	REIFENHALTER VM3 (2.15") RIM LOCK	2
33	564.10.100.100	REIFENHALTER VM4 (2.50") RIM LOCK	2
40	502.10.085.000	STECKACHSE HINTEN '87 L=263MM AXLE CPL.	1
41	565.10.084.000	KETTENSPIANNER CHAIN ADJUSTER	1
42	0933 080453	SK-SCHRAUBE DIN933-M8X45 HEX HEAD SCREW	2
43	0934 080003	SK-MUTTER DIN934-M8 HEX NUT	2
44	543.10.099.000	SK-MUTTER M20X1,5 AXLE NUT	1
50	581.10.040.500	BREMSSATTELTRÄGER BREMBO "X" CALIPER SUPPORT	1

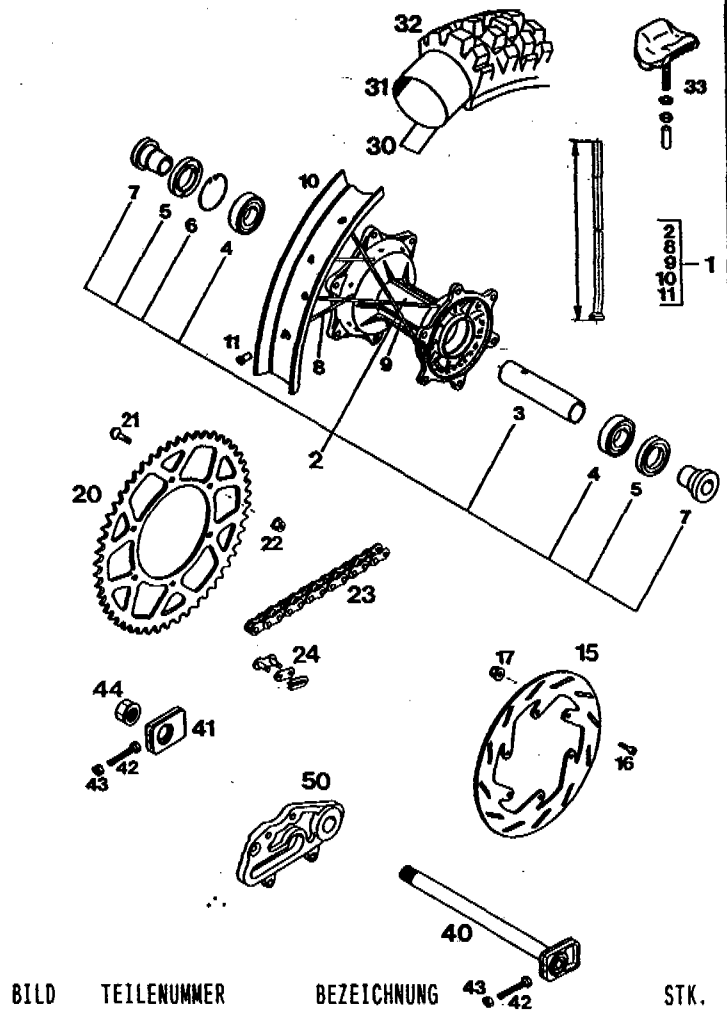
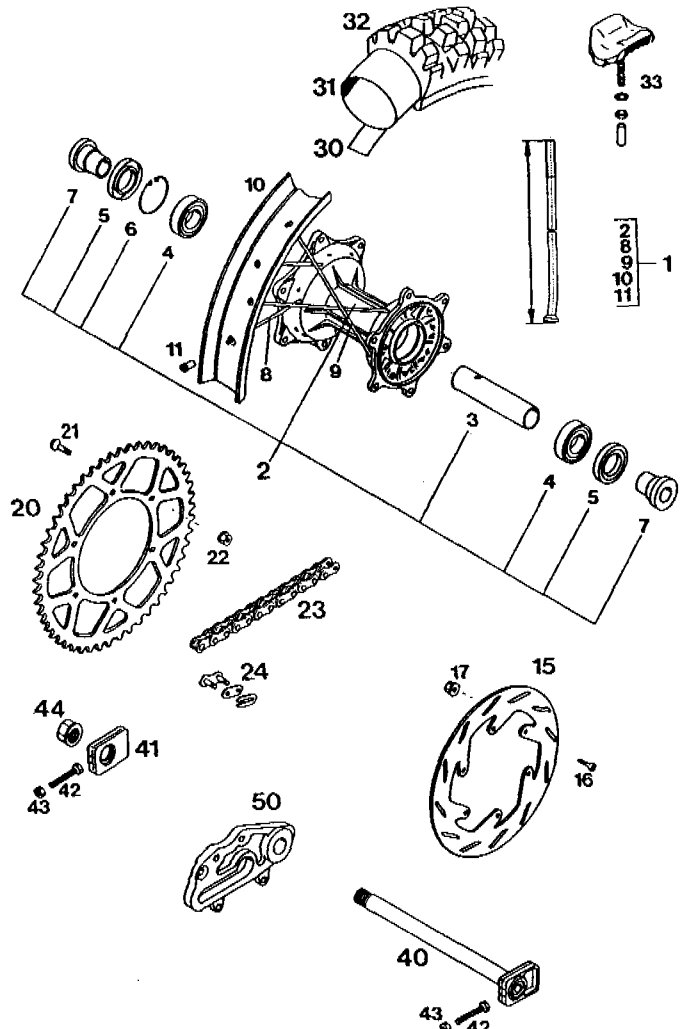

93-502.10.1

BREMSSZANGE HINTEN BREMBO '93
CALIPER REAR

BILD FIG.	TEILENUMMER PART NUMBER	BEZEICHNUNG DESCRIPTION	STK. QTY.
1	580.13.301.644	BREMSSZANGE HINTEN 125/4T '91 CALIPER REAR CPL. SCHWARZ / BLACK / NOIR	1
3	580.13.322.500	BREMSSATTELTRÄGER-HINT. '90 REAR BRAKE SUPPORT	1
9	545.13.209.044	BREMSKLOTZGARN. ORGANISCH 222 BRAKE PAD HARD	1
9	545.13.209.144	BREMSKLOTZGARN. SINTER MD 518 BRAKE PAD SIN.	X
10	545.13.214.000	ENTLÜFTUNGSSCHRAUBE M10X1 BLEEDER SCREW	1
11	545.13.215.000	KAPPE F.ENTLÜFTUNGSSCHRAUBE DUST COVER	1
12	545.13.218.000	MANSCHETTE SLEEVE	1
13	545.13.219.000	MANSCHETTE SLEEVE	1
14*	545.13.205.100	DICHRINGE F. BREMSKOLBEN 34MM SEAL RINGS	1
18	0912 080103	ISK-SCHRAUBE M 8 X 10 A H SCREW	2
19	360.03.014.000	SCHNORR-SICHERUNGSSCHEIBE 8MM LOCK WASHER	2
22	545.13.027.000	BREMSSCHLAUCH-GI HINTEN 890 MM BRAKE HOSE REAR	1
30	420.13.226.000	DICHRING 10 X 16 X 1 CU SEAL RING CU.	1
31	420.13.026.000	DICHRING 10 X 16 X 1,5 CU SEAL RING CU.	1
35	502.13.025.000	HOHLSCHRAUBE M10X1X19 CONNECTING SCREW	1

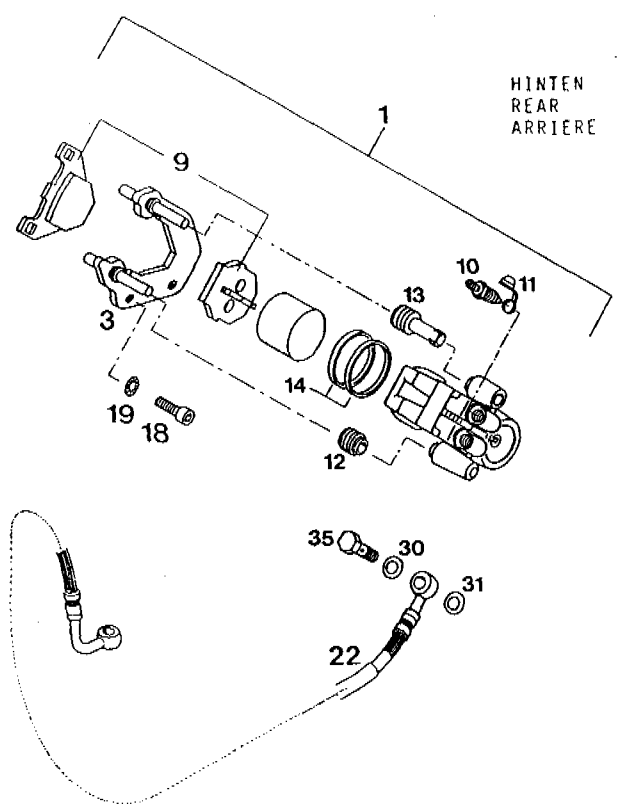

HINTEN
REAR
ARRIERE